



CONTROLLER MANUAL FOR CHILLERS AND INVERTER AIR/WATER HEAT PUMPS WITH AXIAL FANS

Models THRON AGR2



This manual has been created for informative purpose. The company declines any responsibility for the results of any projecting or any installation based on the explanations and/or on the technical specifications provided in this manual. It is besides forbidden the reproduction under any form of the texts and of the figures contained in this manual.

"This manual is a translation from the official italian language version. For reasons of environmental respect the Company will not provide the hard copy in the original language which could be directly requested or downloaded from the Company website at any time. In case of any dispute, the original language manual will be the trusted one".

01	03-2017		
00	08-2014		
Rev	Date	Author	Supervisor

Catalogo / Catalogue / Katalog / Catalogue MCO14124H7820-01	Serie / Series / Serie / Serie / Série CONTROLLER FOR CHILLERS AND INVERTER AIR/WATER HEAT PUMPS WITH AXIAL FANS
---	--

Possible wasted electrical or electronic devices/products should not be located together with normal domestic waste, but disposed according to the current WEEE law in compliance with the European Directive 2002/96/EC and following modifications 2003/108/EC. Please inform yourself at your local Administration or at your reseller in case the product will be replaced with a similar one.



INDEX

1	CONSERVATION OF THE MANUAL	4
1.1	GRAPHIC SYMBOLS	4
2	PERMITTED USES	4
3	GENERAL SAFETY RULES	4
3.1	PERSONAL SAFETY EQUIPMENTS	4
3.2	WORKERS' HEALTH AND SAFETY	4
4	PURPOSES AND CONTENTS OF THE MANUAL	6
5	USER'S INTERFACE - CONTROLER	6
5.1	MENU STRUCTURE DIAGRAM	6
5.1.1	ANALOG INPUT MENU	7
5.2	PARAMETERS CATEGORIES	7
5.3	SETPOINT ADJUSTABLE BY THE USER	7
5.4	DISPLAY	8
5.5	LED	8
5.6	INPUT/OUTPUT (I/O) PORTS	8
6	DYNAMIC SET-POINT ADJUSTMENT	9
7	SET-POINT ADJUSTMENT FROM 0-10V INPUT	9
8	CIRCULATOR	10
8.1	OPERATION BY MEAN OF THERMOREGULATOR (DEFAULT)	10
8.2	OPERATION BY THERMOREGULATOR WITH PERIODIC ACTIVATION	11
8.3	OPERATION WITH ACTIVE ELECTRIC HEATER	11
8.4	CONTINUOUS OPERATION	11
8.5	PROPORTIONAL ADJUSTMENT OF THE PUMP	11
8.6	PURGING THE SYSTEM	12
9	HEAT DISSIPATION FAN MOTOR CONTROL	12
9.1	FAN SPEED CONTROL IN COOLING MODE	12
9.2	FAN SPEED CONTROL IN HEATING MODE	13
10	CONTROL FUNCTIONS	13
10.1	ALARM WARNING	13
10.2	ANTIFREEZE PROTECTION ELECTRIC HEATERS (WHEN THE PAG ACCESSORY IS PRESENT)	13
10.3	ACTIVATION OF SANITARY (DOMESTIC) HOT WATER PRODUCTION	13
10.3.1	SENSOR MEMORIZATION IN HEATING MODE	14
10.4	HEATING MODE ON SANITARY ACCUMULATION	15
10.5	REMOTE FUNCTIONS	16
10.5.1	ON/OFF	16
10.5.2	SUMMER/WINTER MODE COMMUTATION	16
10.5.3	SANITARY MODE CALL FROM DIGITAL INPUT	16
10.6	REMOTE SENSOR FOR THE WATER TEMPERATURE OF THE PLANT CIRCUIT	17
10.7	AUXILIARY ELECTRIC HEATER	17
10.7.1	PLANT CIRCUIT ELECTRIC HEATER	17
10.7.2	AUXILIARY ELECTRIC HEATER OF THE PLANT IN DEFROST CYCLE	17
10.7.3	ELECTRIC HEATER OF SANITARY WATER PRODUCTION	18
10.7.4	A UNIQUE AUXILIARY ELECTRIC HEATER FOR BOTH PLANT SYSTEM/DHW PRODUCTION	18
10.8	SELECTION MODE OF AUXILIARY ELECTRIC HEATERS	18
10.9	MANAGEMENT OF THE CIRCULATOR WITH ACTIVE ELECTRIC HEATER	18
10.10	BOILER ENABLEMENT	18
10.11	ACTIVATION OF AUXILIARY ELECTRIC HEATERS AND BOILER DURING THE JOINT AND IN SUBSTITUTION OPERATION TO THE COMPRESSOR OF THE HEAT PUMP	19
10.11.1	OPERATION IN HEAT PUMP MODE	19
10.11.2	IN JOINT OPERATION (AREA I)	19
10.11.3	IN JOINT OPERATION (AREA II)	19
10.11.4	IN SUBSTITUTION OPERATION	20

10.12	OPERATION AREA - ACTIVATION OF THE AUXILIARY ELECTRIC HEATER AND BOILER (PLANT CIRCUIT WATER TEMPERATURE SENSOR IS NOT ENABLED).....	20
10.12.1	<i>AUXILIARY SYSTEMS OFFSET MANAGEMENT</i>	23
10.13	SUMMER/WINTER OPERATION INDICATION	24
10.14	DEFROSTING CYCLE	24
10.15	COMPRESSOR CRANCKASE HEATER	24
10.16	MANAGEMENT OF THE SECONDARY CIRCULATOR/RELAUNCHING PUMP (WITH ROOM THERMOSTAT)	24
10.17	MAXIMUM Hz	25
10.18	DOUBLE SET-POINT (WITHOUT REMOTE CONTROL HI-T)	25
10.18.1	<i>CONTROL SETTINGS</i>	25
10.18.2	<i>NOTES FOR INSTALLATION</i>	25
10.18.3	<i>HUMIDISTAT OPERATION</i>	26
10.18.4	<i>ADJUSTABLE SET-POINT</i>	26
10.18.5	<i>COMMUTATION</i>	26
10.18.6	<i>HUMIDISTAT WIRING</i>	27
11	AVAILABLE FUNCTIONS WITH HI-T ACCESSORY	27
12	AVAILABLE FUNCTIONS WITH KIE MODULE (OPTIONAL)	27
13	HANDBOOK FOR CONFIGURATIONS OF INSTALLATION	27
14	TABLES OF CONFIGURATIONS ALLOWED TO USER AND INSTALLER V4.....	27
15	ALARMS	33
15.1	WATER FLOW SWITCH E06	33
15.2	HIGH TEMPERATURE E18.....	33
15.3	ANTI-FREEZING E05	33
15.4	SENSORS ALARM E611÷E691	33
15.5	TIMEOUT INVERTER E801	33
15.6	INVERTER [E851÷E971].....	33
15.7	REMOTE ON/OFF E00	33
15.8	HIGH PRESSURE E01	33
15.9	HIGH PRESSURE FLOW SWITCH (IN SERIES WITH THE COMPRESSOR OUTLET PROBE) E641	33
15.10	LOW PRESSURE E02.....	33
15.11	[E08] RIVER LIMITATION	33
15.12	POWER FAILURE.....	34
15.13	USER BLOCK ALARM LIST	34





1 CONSERVATION OF THE MANUAL

The manual has to be always kept for future reference. It has to be stored in a safe place, away from dusts and moisture. It has to be also available and accessible to all users who shall consult it any time they are in doubt on how to operate the equipment. The company reserves the right to modify its products and related manuals without necessarily updating previous versions of the reference material. It declines also any responsibility for possible inaccuracies in the manual if due to printing or transcription errors.

The customer shall store any updated copy of the manual or parts of it delivered by the manufacturer as an attachment to this manual.

The company is available to give any detailed information about this manual and to give information regarding the use and the maintenance of its own units.

1.1 GRAPHIC SYMBOLS

	<i>Indicates prohibited operations.</i>
	<i>Indicates operations that can be dangerous for people and/or disrupts the correct operation of the equipment.</i>
	<i>Electric shock hazard - risk of electric shock.</i>
	<i>Indicates important information that the operator has to follow in order to guarantee the correct operation of the equipment in complete safety. It indicates also general notes.</i>

2 PERMITTED USES

The company excludes any contractual and extra contractual liabilities for damages caused to persons, animals or objects, by incorrect installation, setting and maintenance, improper use of the equipment, and the partial or superficial reading of the information contained in this manual.

These units have been designed only for heating and/or cooling water. Any other use not expressly authorized by the manufacturer is considered improper and therefore not allowed.

The location of the plant, the hydraulic and electrical circuits must be established by the planting designer and must take into account both technical requirements as well as any applicable local laws and authorized specifications.





The execution of all works must be performed by skilled and qualified personnel, competent in the existing rules in different countries.

3 GENERAL SAFETY RULES

Before beginning to operate on the units every user has to be perfectly knowledgeable about the functions of the equipment and its controls and has to have read and understood the information listed in the user's-installer's manual.

3.1 PERSONAL SAFETY EQUIPMENTS

During the operating and maintaining works, use the following personal protective equipment.

	<i>Protective clothing: Maintenance men and operators have to wear protective clothing that complies with the basic safety requirements currently in force. In case of slippery floors, users have to wear safety shoes with non-slip soles.</i>	
	<i>Gloves: During maintenance or cleaning operation protection gloves have to be used</i>	
		<i>Mask and goggles: Respiratory protection (mask) and eye protection (goggles) should be used during cleaning and maintenance operations.</i>

3.2 WORKERS' HEALTH AND SAFETY

The European Community has adopted a number of directives on workplace's health and safety, which include 89/391/CEE, 89/686/CEE, 2009/104/CE, 86/188/CEE and 77/576/CEE directives. Every employer shall implement such provisions and ensure that their workers to respect them.



It's forbidden:

- *To remove and/or tamper with any safety device.*
- *The access to the electrical board by unauthorized persons*
- *To carry out any work on the equipment under voltage*
- *To touch the equipment if you are not allowed.*
- *The use of the appliance by children or unassisted disabled persons.*
- *To touch the appliance when barefoot or parts of the body are wet or damp*
- *To clean the unit when the power is 'ON'.*
- *To pull, remove or twist the electrical cables coming out from the unit.*

- *To step with your feet on the appliance, sit down and/or place any type of object.*
- *To spray or pour water directly on the unit.*
- *To dispose of, abandon or leave within reach of children packaging materials (cardboard, staples, plastic bags, etc.) as they may represent an environmental and health hazards.*
- *To tamper with or replace parts of the equipment without the specific consent of the manufacturer. The manufacturer shall have no whatsoever civilian or penal responsibility in case of unauthorized operations.*



WARNING:

- *Before proceeding, you should read the user's-installer manual accompanying appliance.*
- *All the operations described below must be carried out only by QUALIFIED PERSONNEL.*
- *The wiring to the terminal block must be performed by qualified personnel.*
- *Any routine and/or not-routine maintenance operation shall be carried out when the equipment has been shut down, disconnected from electric power supply.*
- *Do not put neither your hands nor insert screwdrivers, spanners or other tools into moving parts of the equipment*
- *The equipment's supervisor and the service man have to receive suitable training for performing their tasks in safety.*
- *The access to the electric panel is limited to authorized personnel only.*
- *Operators have to know how to use personal protective devices and have to know the accident-prevention guidelines contained in national and international laws and norms.*
- *The operator's workplace has to be kept clean, tidy and free from objects that may prevent free movements. Appropriate lighting of the work place shall be provided so as to allow the operator to carry out the required operations safely. Poor or too strong lighting can cause risks.*
- *Ensure that the work places are always adequately ventilated and that aspirators are working, in good condition and in compliance with the requirements of the laws in force.*
- *Not all the configurations can be simultaneously enabled and/or changed.*
- *Other values different than those of default can ensure the proper operation of the unit, in case of doubt about the value to be set contact please our office.*
- *The company excludes any contractual and extra contractual liabilities for damages caused to persons, animals or objects, by incorrect installation, setting and maintenance, improper use of the equipment, and the partial or superficial reading of the information contained in this guide.*



- *The supply voltage's fluctuations cannot exceed $\pm 10\%$ of the nominal value. If this tolerance should not be respected, please contact our technical department.*
- *The power supply should respect the listed limits: failing this, warranty will not be valid immediately. Before any operation on the unit, be sure that the power supply is disconnected.*
- *Phase, neutral and ground connections should be respected.*
- *The power supply cables must be sized correctly. We recommend a minimum cross section of 4mm^2 and a maximum length of 10m.*
- *Install upstream of each unit an adequate protection and disconnection device of the electric power with delayed characteristic curve, with at least 3 mm contact opening and with an adequate capacity of breaking and differential protection. The capacity of the magneto-thermic circuit breaker must conform to the electric consumption of the unit; see TECHNICAL DATA reported in the user's-installer's manual accompanying the unit. (Consideration should be taken of any eventual auxiliary electric heater).*
- *A good grounding is required; the manufacturer is not responsible for damage caused in case of lack of good grounding.*
- *In case of maintenance, the unit must be disconnected from the power supply, the power cable plug must be easy for pulling it out from the power socket by the operator for having possibility to check the unit from anywhere, the plug should remain disconnected.*
- *Use cables that meet the regulations in force in different countries.*
- *Be sure, after about 10 minutes of operation the screws on the power supply terminal block that are well fixed.*



Requirements before performing electrical work on the control panel:

- *Turn off the unit from the control panel ("OFF" displayed).*
- *Put the switch "QF" general differential on OFF position*
- *wait for 15 seconds before getting access to the electric board*
- *Check the ground connection before beginning any operation.*
- *Be sure that you are well insulated from the ground, with dry hands and feet, or by using insulating platforms and gloves.*
- *Check that there is no foreign material near the system.*

4 PURPOSES AND CONTENTS OF THE MANUAL

This manual provides basic information for the installation, operation and maintenance of CHIP units.

It is addressed to machine operators and it enables them to use the equipment efficiently, even if they do not have any previous specific knowledge of it.

Not all the described functions can be individually and/or simultaneously selected. Please contact the technical office for any information.

The manual describes the characteristics of the equipment at the time in which it is being put on the market; therefore, it may not include technological improvements introduced later by the company as part of its constant endeavour to enhance the performance, ergonomics, safety and functionality of its products.

The company introduces also technological improvements and is not constrained to update the manuals for previous versions of appliances that could not be compatible. So make sure to use manual supplied with the installed appliance.

It's recommended that, the user must follow the instructions contained in this booklet, especially those concerning the safety and routine maintenance.

5 USER'S INTERFACE - CONTROLER



**MODE
ESC**

It is used to select the operating mode, and to reset the manual resetting alarms. The operating mode changes as per the sequence below each time you press the Mode button:

off → cool → heat → off

If the Domestic Hot Water (DHW) mode is enabled, the sequence is as follows:

off → cool → cool+san → heat → heat+san → off

During the parameters' setting, this button can be used to revert BACK to the previous level.

PRG

It allows you to enter into the setting menu parameters and to select the cool/summer, heat/winter and DHW set point value.



UP button: In the setting mode, this button allows you to move up to a higher menu or to increase the value of a parameter when you are in the "edit" mode.



DOWN button: In the setting mode, this button allows you to shift to a lower menu or to decrease the value of a parameter when you are in the "edit" mode.

5.1 MENU STRUCTURE DIAGRAM

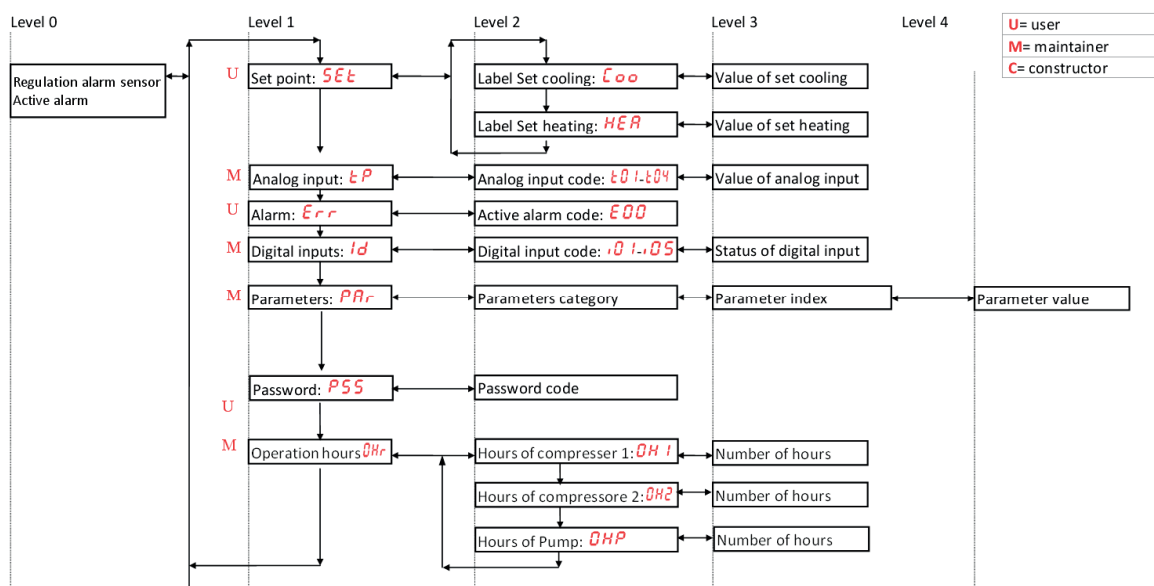

Level 0 (U) = always appearing

Level 1 (M) = it appears if you enter the maintainer (H80) or manufacturer password.

Level 2 (C) = it appears if you enter the manufacturer password.

Level 3 (A) = it appears only via Modbus.

5.1.1 ANALOG INPUT MENU

By entering the maintainer password in the menu of analog inputs "tP", at the level 1 of the menu structure diagram of the unit control board, you can read the values of the current probes:

tp	DESCRIPTION	Measurement unit
t01	Inlet water temperature	(°C)
t02	Outlet water temperature	(°C)
t03	Compressor inlet temperature	(°C)
t04	Compressor outlet temperature	(°C)
t05	High pressure	(bar)
t06	Low pressure	(bar)
t07	Outdoor air temperature	(°C)
t08	Plant remote temperature sensor (if enabled)	(°C)
t09	Domestic hot water temperature (if DHW is enabled)	(°C)
t10÷t27	Parameters presents if installed the optional KIE module	-

5.2 PARAMETERS CATEGORIES

The parameters are classified into groups, each group is identified by a 3-digit code, while the index of each parameter is preceded by one letter.

DESCRIPTION	GROUP IDENTIFICATION CODE	PARAMETER INDEX	VISIBILITY
Configuration	CnF	H-	USER / INSTALLER
Compressor	CP	C-	INSTALLER
Fan	FAn	F-	INSTALLER
Alarms	ALL	A-	INSTALLER
Regulation	Re	b-	INSTALLER
Pump	PUP	P-	INSTALLER
Electric heater	Fro	r-	INSTALLER
Defrost	dFr	d-	INSTALLER
Electronic valve	EEu	U-	INSTALLER
Offset	OFF	o-	INSTALLER
Mixer valve	rAd	i-	INSTALLER
**Solar	SUn	S-	INSTALLER
Inverter compressors	nCP	n-	INSTALLER
Hz massimi	LbH	L-	UTENTE/INSTALLATORE
* DHW preparer	AcS	Ac-	USER / INSTALLER

(*) Programmable parameters if the optional KIE module is present

5.3 SETPOINT ADJUSTABLE BY THE USER

SETPOINT	DESCRIZIONE	UNITA'	DEFAULT	RANGE
Coo	setpoint in Estate	°C	7.0	5÷18
Hea	setpoint in Inverno	°C	45.0	35÷57
*San	DHW mode setpoint	°C	48.0	25÷57
Co2	Secondo setpoint in Estate	°C	18.0	Coo÷23
He2	Secondo setpoint in Inverno	°C	35.0	25÷Hea
**rCO	Mixer valve setpoint in Summer mode	°C	15.0	-50.0÷80.0
**rHE	Mixer valve setpoint in Winter mode	°C	30.0	-50.0÷80.0
**ACS	DHW instantaneous production setpoint	°C	45.0	0.0÷80.0

(*) Adjustable Setpoint if the DHW mode is active

(**) Adjustable Setpoint if is intalled the optional KIE module









Setpoint type	Setpoint (summer/winter)	Summer default (range)	Winter default (range)
First setpoint (°C)	Coo/Hea	7 (5÷18)	45 (35÷55)
Second setpoint (°C)	Co2/He2	18 (7÷23)	35 (25÷45)
Sanitary Setpoint (°C)	San	48 (25÷55)	

The functionality of the second setpoint can be used only when you purchase the proper optional kit.

5.4 DISPLAY

In Normal view displays the outlet water temperature reported to tenths of degrees, or the alarm code if at least an alarm is active. In case of multiple alarms activation, it will display the first alarm, while the second appears when the first is reset. Into the menu mode, the display depends on the current position where you are.

5.5 LED

	Compressor LED	ON if the compressor is running OFF if the compressor is off FLASHING if timings are in progress waiting for compressor's start up
	Sanitary water LED	ON if sanitary mode is active OFF if the sanitary mode is not active FLASHING if sanitary production in progress (sanitary valve is active)
	Defrosting LED	ON in defrost operating mode OFF if defrosting mode is disabled or completed FLASHING if defrosting cycle interval's time is in progress.
	Antifreeze electric heater LED	The LED is ON if the antifreeze electric heater is active.
	Water pump LED	The LED is ON if the water pump is running.
	Alarm LED	The LED is ON if an alarm is activated.
	Heat LED	The LED is ON if the unit is in the heating mode operation.
	Cool LED	LED is ON if the unit is in the cooling mode operation.

5.6 INPUT/OUTPUT (I/O) PORTS

The I/O (inputs and outputs) that can be set to enable the control functions are listed below.

In order to set the I/O please enter with service password to the parameters **PRG**→**PSS**→**PRG** → (insert the service password) → **PRG** → **Par** → **PRG** → **CnF**.

Ports	Parameter	Terminals	Factory Setting		Description
			Value	Function	
ST8	H19	SE/SE	0	Not set	Programmable analog input with NTC sensor 10kΩ at 25°C β 3435
ST9	H20	SAN/SAN	0	Not set	Programmable analog input with NTC sensor 10kΩ at 25°C β 3435
ID2	H39	ONOFF/ONOFF	2	Remote on/off (See paragraph 10.5.1)	Voltage free contact digital input
ID3	H40	SW/SW	3	Remote summer/winter commutation (See paragraph 10.5.2)	Voltage free contact digital input To activate this function see paragraph 10.5.2
ID7	H44	SE/SE	0	Not set	Voltage free contact digital input, programmable instead of the analog input ST8 (H19=0)
ID8	H45	SAN/SAN	0	Not set	Voltage free contact digital input, programmable instead of the analog input ST9 (H20=0)
DO3	H58	AEH (phase) AEHN (neutral)	22	Command of the plant auxiliary E-heater (See paragraph 10.7.1)	Under voltage output single phase 230Vac, 50Hz, 5A resistive, 1A inductive. To activate this function see paragraph 10.7.1
DO4	*H59	DO4 (phase) DO4N (neutral)	0	Not set	Under voltage output single phase 230Vac, 50Hz, 5A resistive, 1A inductive.
DO5	*H60	DO5 (phase) DO5N (neutral)	0	Not set	Under voltage output 230V ac, 50Hz, 5A resistive, 1A inductive.
OC1	H61	NO1 (phase) N1 (neutral) NC1 (phase)		Command of DHW valve (See paragraph 10.3)	Switching contact, single phase voltage 230Vac, 50Hz, 5A resistive, 1A inductive. NO1= Normally open NC1= Normally-Closed To activate this function see paragraph 10.3
OC2	H62	NO2 (phase) N2 (neutral) NC2 (phase)		Command of Double setpoint valve (See paragraph 10.17)	Switching contact, single phase voltage 230 ac, 50Hz, 5A resistive, 1 A inductive. NO2= Normally open NC2= Normally-Closed To activate this function see paragraph 10.17

(*) Do not change if the KA kit is installed is present

Note: Note that with the adoption of the optional “KIE” module helps to increase the input/output (I/O) ports. For more information, please refer to the related manual of this module.

6 DYNAMIC SET-POINT ADJUSTMENT

The controller can change the set-point by adding a value depending on the outdoor air temperature sensor. In this case, you need to change the values of the parameters from **b08** to **b14** following the indications below (the settings should be done by the installer):

Parameters of the controller **PAr->rE->**

- **b08** = dynamic set-point, enabled = 1/ disabled = 0.
- **b09** = offset max in cooling mode operation.
- **b10** = offset max in heating mode operation.
- **b11** = Outdoor temperature setting in cooling mode.
- **b12** = Outdoor temperature setting in heating mode.
- **b13** = Temperature difference in cooling mode operation.
- **b14** = Temperature difference in heating mode operation.

Curve of the set-point variation as a function of the outside temperature:

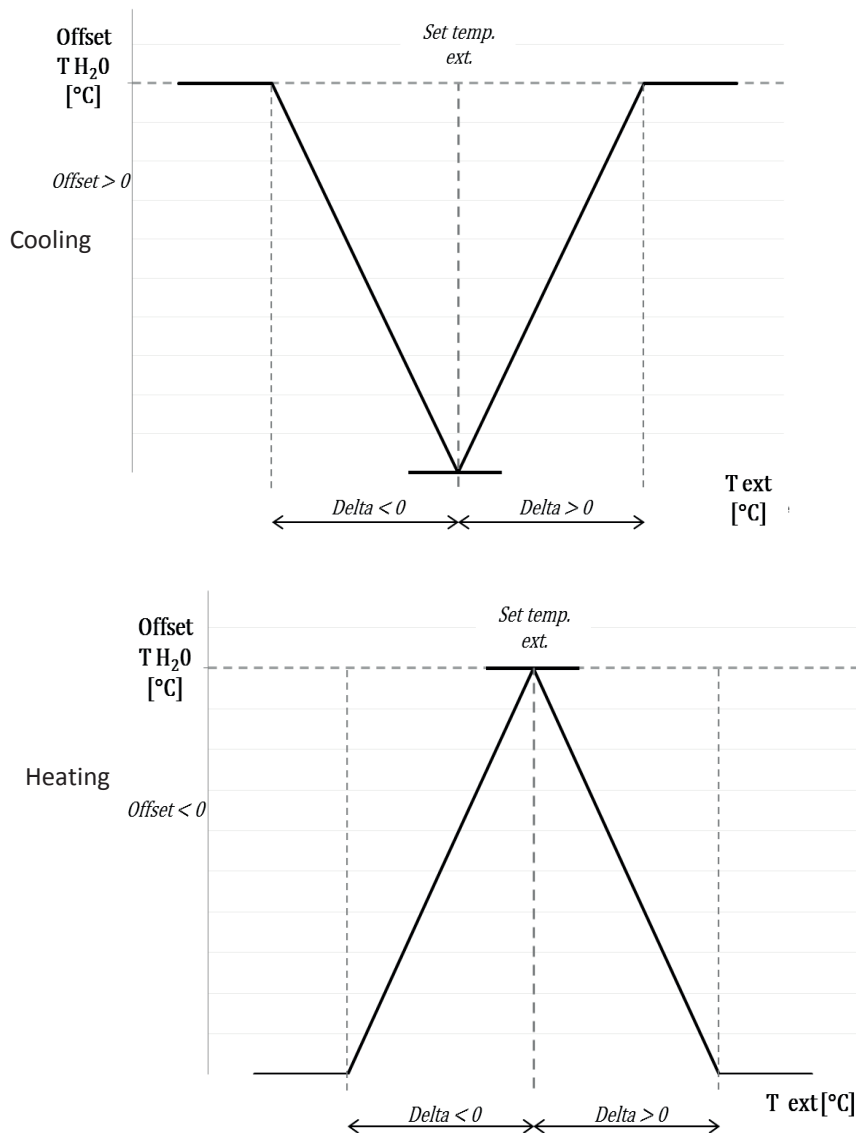

7 SET-POINT ADJUSTMENT FROM 0-10V INPUT

Another type of setting that allows to change the set-point by adding (or subtracting) a value in function of the 0-10V analogue input (if enabled). To enable the function, you must set the **H21** parameter to be **40**, and change the values of the parameter **b15** (range 0-10), taking into account that if **b20=0** input of 0-10V, if **b20=1** ratiometric input type:

- **b20=0** if this input is at 0 volts you will have the actual set point: **set point (Coo/Hea) - b15/2**.
- **b20=0** if the input is at 5 volts the set point will be the set of (Coo/Hea) mode.
- **b20=0** if the input is 10 volts you will have the actual set point: **set point (Coo/Hea) + b15/2**.

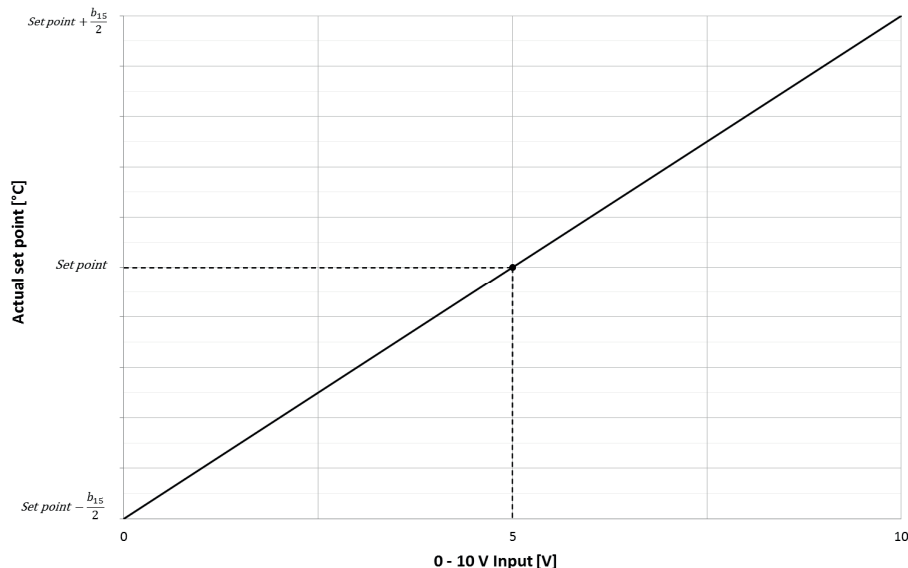

- - **b20=0** when the input is at 0%, the actual set point is: **set point (Coo/Hea) - b15/2**.
- - **b20=0** when the input is at 50%, the set point will be the set of **(Coo/Hea) mode**.
- - **b20=0** if the input is 100%, the actual set point is: **set point (Coo/Hea) + b15/2**.

The signal must be applied to the terminals 0-10V+ and 0-10V- (see the wiring diagrams).

Note: In "cooling" mode, considering that the set-point by default is set to be 7°C, the parameter (**b15**) should not assume any value greater than or equal to 6 in order to prevent that the new set-point set from 0-10V input to take values below the threshold of the antifreeze operation which is 4°C.

8 CIRCULATOR

The circulating pump can be set according respecting the following operating modes:

- Thermoregulatory operation (default)
- Thermoregulatory operation with periodic activation
- Continuous operation

The circulator will switch off immediately if:

- Presence of blocking pump alarm including the manual reset alarm of the flow switch;
- The unit is off or in stand-by mode or when it's switched off from remote input, the circulating pump (if is ON) will always turn off after **P02** (tenths of a minute):

The circulator is always running if the antifreeze heaters are activated.

The circulator can be configured with the parameter **P03** in order to operate independently than the compressor or under call.

- 0=Continues operation
- 1=Operation under thermoregulatory call

Note: If the automatic reset alarm of the flow switch is active, the pump is anyway in operation even if the compressor is off. Contrarily, the circulator remains always in operation if the antifreeze heaters are on or when the hydraulic pump operates in antifreeze mode. The operation in antifreeze mode will start if the water setting temperature decreases below P04 °C (default value 5°C), and it will be disabled if the water setting temperature increases above P04+P05 °C (the default value of P05 is 2,0°C). The adjustment of the circulator is linear (see Paragraph 8.5).

8.1 OPERATION BY MEAN OF THERMOREGULATOR (Default)

During this operating mode (**P03=1**, default), the thermoregulator actuates the pump; after a time delay of **P01** seconds from startup of the pump, the compressor also will turn on. However, during the power off status, the pump turns off with a delay time of **P02** minutes after turning off status with thermoregulator call (the turning off status is corresponding to the off status of the compressor).

In the case of activation of the flow switch alarms with automatic reset, the pump remains still in operation even if the compressor is stopped.

If you enable the operation of the unit from the remote "on-off" digital input (see Paragraph 10.5.1) the circulating pump will be activated immediately for a duration of 2 minutes regardless of the on-board controller thermoregulation of the unit (the activation of water recirculation in the plant leads to a correct activation of the thermoregulation).

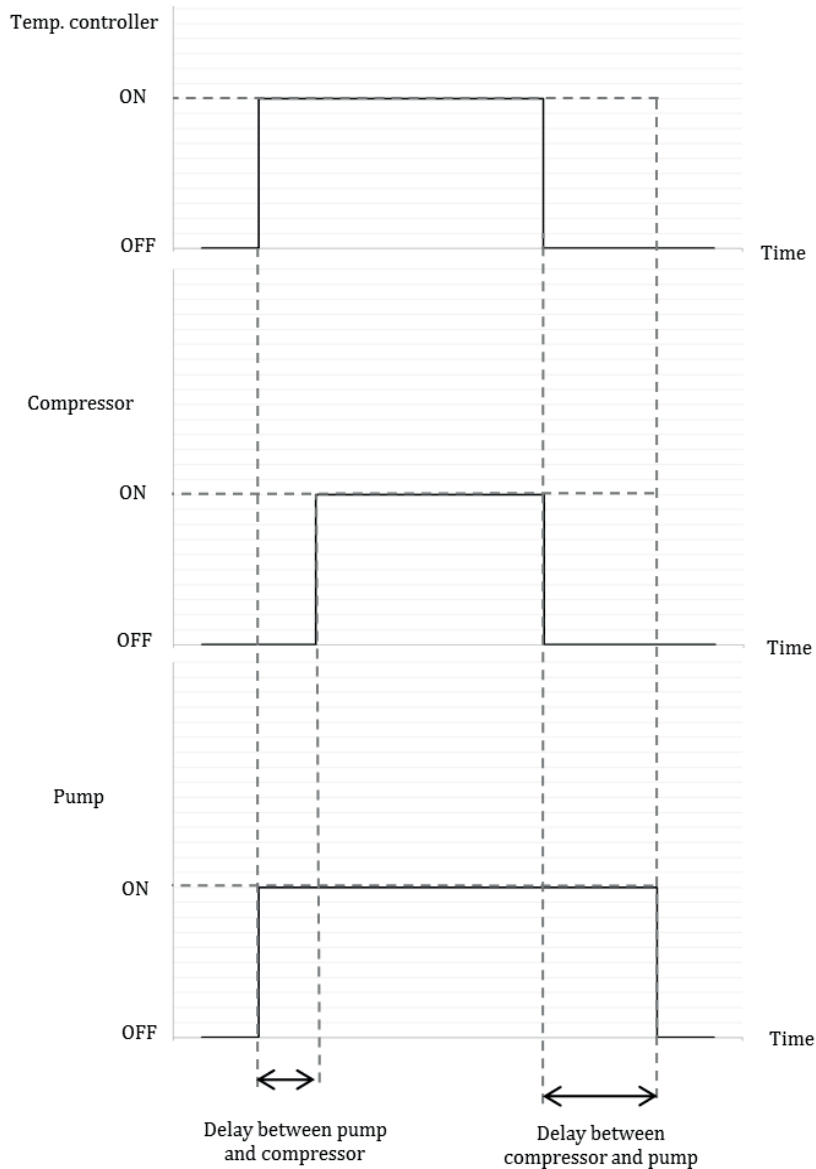

8.2 OPERATION BY THERMOREGULATOR WITH PERIODIC ACTIVATION

The function is disabled if **P17= 0** (default). If the pump is set to operate by thermoregulation call (**P03 = 1**, default), it will be activated periodically for a time period defined by the parameter **P17** (in seconds) after a counting time set by the parameter **P16** (in minutes), activated when the pump is turned off for satisfied thermoregulation.

In the case of the activation of the flow switch alarm with automatic reset the pump is still operating even if the compressor is off. The periodic function is also interrupted in the case of the intervention of the antifreeze thermo-regulator constraining the operation of the pump.

8.3 OPERATION WITH ACTIVE ELECTRIC HEATER

See paragraph 10.9.

8.4 CONTINUOUS OPERATION

In this operating mode (enabled if **P03=0**), the pump is always running. It turns off only when the unit is in OFF status. The pump is always ON even if automatic reset flow switch alarm is ON and even the compressor is off.

8.5 PROPORTIONAL ADJUSTMENT OF THE PUMP

The pump speed can change as a function of the temperature difference between the water inlet and the water outlet of the heat exchanger, according to the diagram shown below, where:

P07: maximum speed of the modulating pump (%)

P08: minimum speed of the modulating pump (%)

P09: set Delta T inlet/outlet water of the modulating pump (°C)

P10: Delta modulating pump (°C)

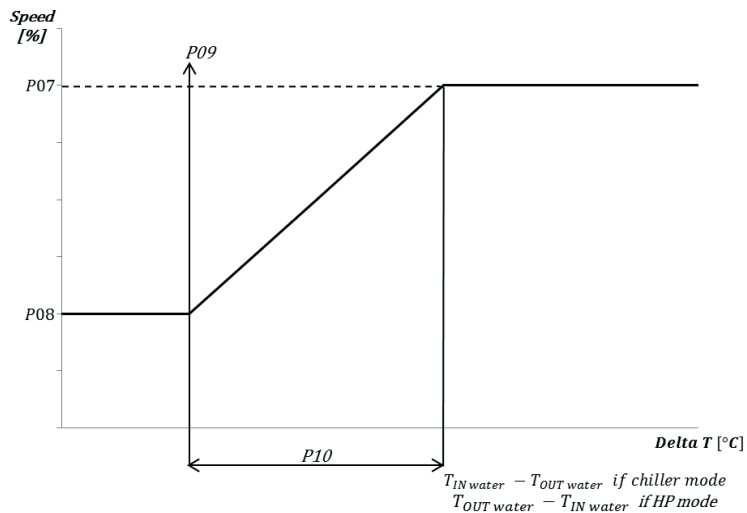

In domestic hot water production mode, the pump will operate at the maximum speed.

Note: If the parameter r33>0, then the circulator can start operations under call also for the activation of the plant resistance and/or sanitary mode operation, see paragraph. **Errore. L'origine riferimento non è stata trovata..**

8.6 PURGING THE SYSTEM

This function allows purging the system using the circulator at the maximum speed.

To enable the function:

- Control in **OFF** mode
- Enter into the parameters PRG→PSS→ PRG → (introduce the Maintainer password)
- Press simultaneously for 3 seconds the buttons **UP** and **DOWN**.

The circulator of the system starts operation at the maximum speed, and after **5 minutes** the circulator will stop to operate.

You can manually exit from purging the system cycle by pressing the **MODE/ESC** button, or by pressing simultaneously the **UP** and **DOWN** buttons for 3 seconds.

During this function the flow switch alarm is deactivated.

9 HEAT DISSIPATION FAN MOTOR CONTROL

The control of the dissipation is a function of the condensing pressure in chiller mode and it is a function of the evaporation pressure in heat pump mode.

The adjustment of the fan speed occurs depending on the compressor operation.

9.1 FAN SPEED CONTROL IN COOLING MODE

The fan speed control in cooling mode occurs depending on the diagram shown below, where:

F08 = Pressure set to the minimum fan speed in cooling mode

F09 = Fan proportional band in cooling mode

F10 = Delta cut-off of the fan in heating/cooling mode

F11 = Cut-off hysteresis in cooling/heating mode

F14 = Pressure set to the maximum fan speed in cooling mode

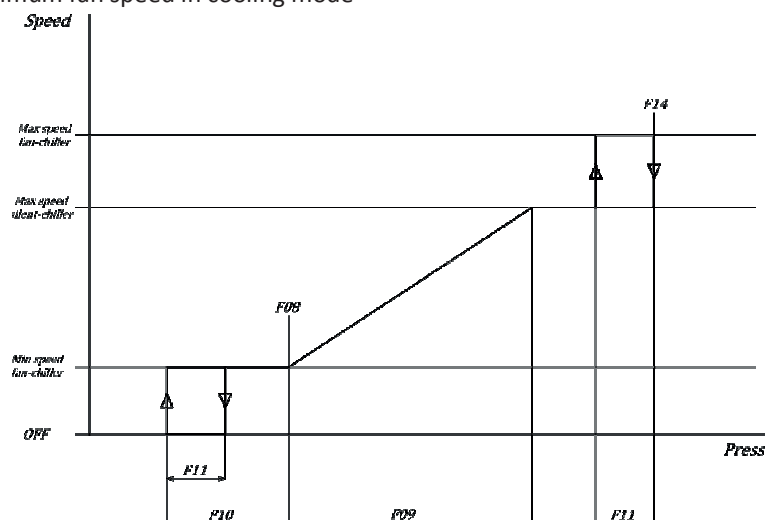

Pre-ventilation period in chiller mode: before the compressor startup, the fan starts operation for 5 seconds; the fan speed is proportional to the condensation temperature, however, if the controller requires the cut-off during this period, the fan motor will

run at preset minimum fan speed. This function has the purpose to prevent the compressor startup at very high condensation temperatures.

9.2 FAN SPEED CONTROL IN HEATING MODE

The fan speed control in heating mode occurs depending on the diagram shown below, where:

F17 = Pressure set for the minimum speed of the fan motor in heating mode

F18 = Fan motor proportional band in heating mode

F10 = Delta cut-off of the fan motor in cooling/heating mode

F11 = Cut-off hysteresis in cooling/heating mode

F20 = Pressure set for the maximum speed of the fan motor in heating mode

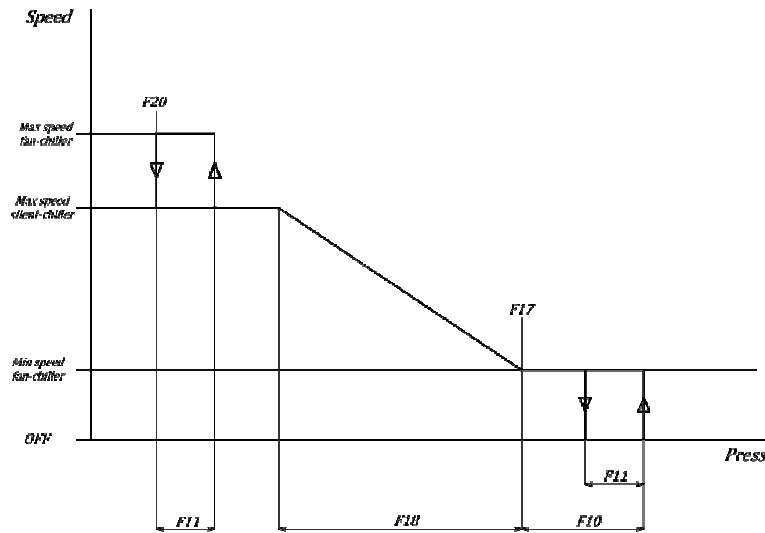

10 CONTROL FUNCTIONS

The functions that can be activated by the on-board unit controller are listed below, these functions are not all selectable at the same time.

Other values different than the default can ensure the proper operation of the unit, in case of doubt about the value that to be set please contact our office.

10.1 ALARM WARNING

You can configure an undervoltage output to warn the presence of an alarm.

In order to enable this function, you should enter into the page of parameters **PRG→PSS** (insert the service password) **→PAr→CnF**

I/O Ports - Parameter	Value	Function
Undervoltage output	24	Alarm notification

10.2 ANTIFREEZE PROTECTION ELECTRIC HEATERS (WHEN THE PAG ACCESSORY IS PRESENT)

The electric heaters of water antifreeze, installed on the outer surfaces of the evaporator plates, activates even when the unit is switched off (but energized) if the outlet water temperature goes below **r02** °C (default is 4°C) in heating mode or below **r03** °C (default is 4°C) in cooling mode and in shut off condition. The same electric heaters are switched off when the temperature measured by the outlet water sensor exceeds **r02+r06** in heating mode or **r03+r06** in cooling mode and in shut off condition (as default value **r06=2,0°C**). The heating cable placed on the basement of the appliance turns on when the outdoor air temperature decreases below 3°C and the unit starts the defrosting cycle (or if **r19=0** even if the unit is not in defrosting cycle, or in stand-by mode). It will be deactivated if the outdoor temperature exceeds 5°C or the last defrosting cycle is concluded after more than **r19** minutes (default 10 minutes) (with **r19≠0**).

10.3 ACTIVATION OF SANITARY (DOMESTIC) HOT WATER PRODUCTION

To activate the hot sanitary water function, be sure to install a temperature sensor inside the tank and to connect it to the **SAN-SAN** terminals (enabled as analog input).

In order to enable this function, you should enter into the page of parameters **PRG→PSS→PRG→** (type the service password) **→PRG→PAr→PRG→CnF**.

See paragraph 14.

I/O Ports - Parameter	Value	Function
H10	0 (default)	Disenbled function
	1	Function is active in heating and cooling mode . The remote on-off function doesn't disenable the DHW production.
	2	Function is active in heating and cooling mode . The remote on-off function disenables the DHW production.
	3	Function is active in heating mode . The remote on-off function doesn't disenable the DHW production.
	4	Active function in heating mode . The remote on-off function disenables the DHW production.
	5	Active function in cooling mode . The remote on-off function doesn't disenable the DHW production.
	6	Active function in cooling mode . The remote on-off function disenables the DHW production.
Analog input	6	Enablement of the DHW temperature sensor.
Undervoltage output (OC1 by default)	6	DHW valve command

If the DHW temperature is below the set point value (set at 48°C by default and adjustable by entering the **PRG->Set->SAN** menu), the unit activates the sanitary valve and the compressor is set at the maximum frequency starting the modulation at one degree before the set value and it stops at one degree after the set value. Once reached the set point value, the valve switches to the stand-by mode and the compressor works normally.

While shifting from user's to domestic hot (sanitary) water, the operating sensor changes from "outlet water sensor" to "sanitary tank sensor". While shifting from the winter operating mode to the sanitary operating mode, the compressor does not switch off, and reaches the maximum established frequency that to be controlled; on the other hand, while shifting from the summer operating mode to the sanitary operating mode, the compressor is switched off to wait for the safety timing.

The defrosting during winter operation mode is always performed on the user side, never on the sanitary water tank.

Note:

- If **H10 = 1**. The remote turning off the unit (remote onoff see paragraph 10.5.1), or by the on board unit controller, or by a remote control board does not affect the sanitary operating mode. The unit starts in sanitary mode as setting priority when it's powered on. The on board unit display shows the temperature measured by the sensor placed inside the sanitary water tank. Once the sanitary cycle is completed, the display returns to show the temperature of the outlet water sensor.

If the remote ON-OFF digital input (onoff-onoff terminals) is open, with the enabling of the domestic hot water production (**H10=1** and **H20=6**), the display on-board unit shows the item "**SAN**". Once the sanitary cycle is concluded, the display returns to show the code "**E00**" indicating that the remote ON-OFF contact is open.

- If **H10 = 2**, the remote on-off function disenables the production of domestic hot water and the operations of the heat pump in heating and cooling on plant side.

Example of activation of this function:

- H10 = 1
- H20 = 6 → DHW temperature sensor [terminals: SAN – SAN]
- H61 = 6(default) → In case of using a 3-way changeover valve with 3 contacts for power supply [terminals: NO1 – N - NC1]
- In case of using a 3-way changeover valve with 2 contacts for power supply (with spring return), [terminals: NO1 – N]

- **Closed contact NO1** means that the valve is energized and diverts the water flow to the DHW tank.
- **Open contact NO1** means that the valve is de-energized and diverts the water flow to users.

10.3.1 SENSOR MEMORIZATION IN HEATING MODE

In the case of commutation from water users to the sanitary water, the temperature sensor changes from a "water outlet temperature sensor" to a "water tank temperature sensor". For such reason, in heating mode, the last value read by the outlet temperature sensor of the heat pump will be memorized before changing to sanitary mode.

When the sanitary thermoregulation is reached, the reference temperature on the plant side will take the value which is previously memorized.

The memory function will be interrupted:

- When the temperature detected by the sensor becomes lower than the memorized value;
- Or after duration equal to **b06** seconds (default 45 seconds).

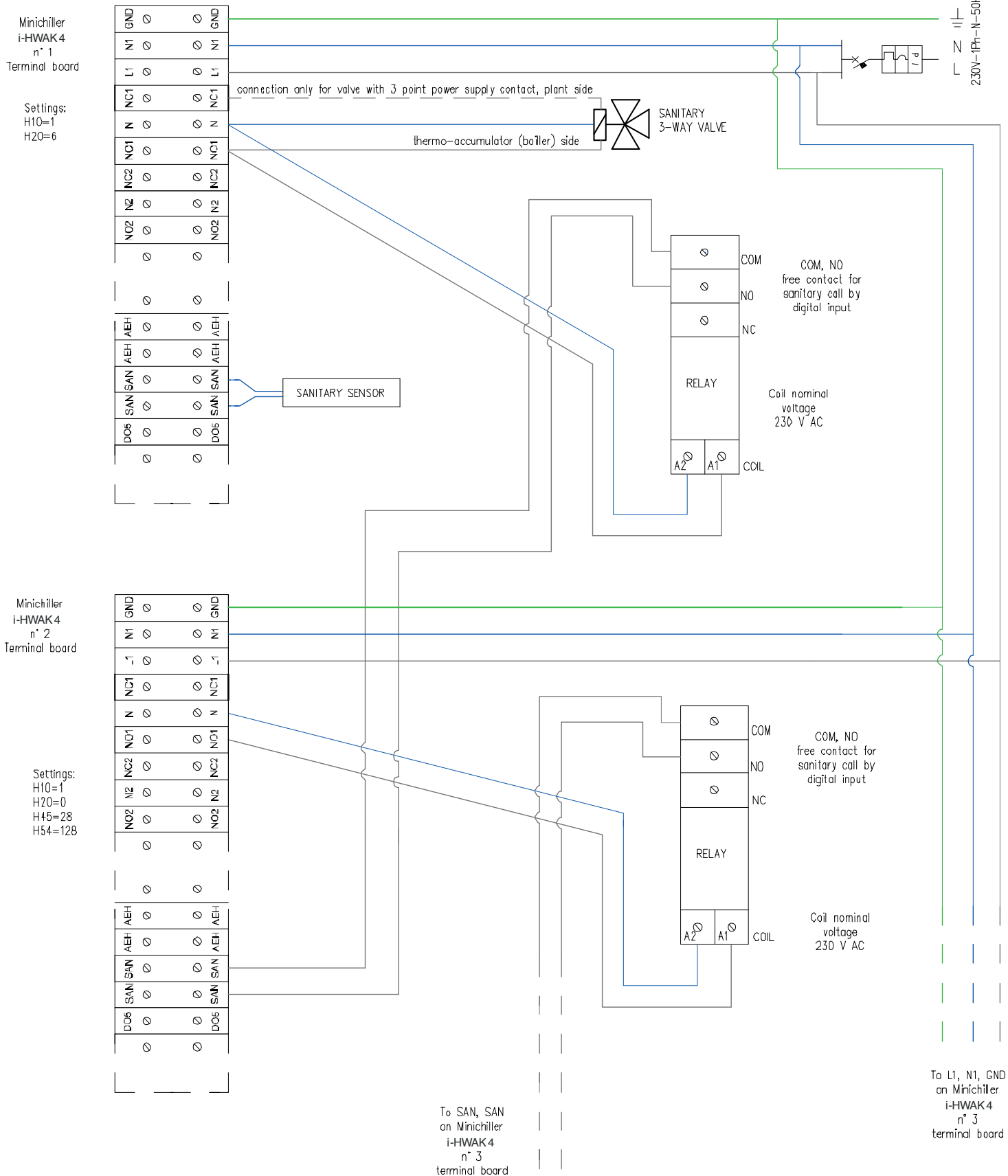

10.4 HEATING MODE ON SANITARY ACCUMULATION

If the parameter **H83=1**, the appliance exploits the accumulation tank for sanitary hot water also to heat the plant side. In these conditions, the relay which controls the sanitary valve will be also energized during heating operation and not only in sanitary mode. During defrost cycle and in cooling mode the valve will be de-energized. When **H83=1**, the sanitary auxiliary electric heater can be enabled also to act as a plant auxiliary electric heater: to this purpose you should set **r10=1** and **r15=2** (for further settings of the parameter **r15** please see Paragraph 10.7.3); also no digital output has to be set for the auxiliary electric heater for the plant.

10.5 REMOTE FUNCTIONS

The terminal block provides the digital inputs to control the unit via an external consent.

10.5.1 ON/OFF

The ON/OFF function is enabled by default on the digital input "ID2" (terminals: ON/OFF-ON/OFF). Remove the bridge of the terminal block then the unit will be placed in stand-by mode (in such status the display of the on-board unit controller will show the "E00" item). When the contact is closed, the machine exits from standby mode and the circulation pump will be activated for 2 minutes.

Enabled function by default (H39 parameter, ON/OFF reference terminal)

I/O Ports - Parameter	Value	Function
Digital input (ID2 by default)	2	Enablement of the remote On/Off function

If the sanitary mode is active and the H10 parameter is set as:

H10 = 1. The remote on-off function has no effect on the production of domestic hot water, it turns off only the heating/cooling operation of the heat pump on plant side (in such case the on-board unit control display shows the item "SAN").

H10 = 2, the on-off remote function turns off the production of domestic hot water and the heating/cooling operating of the heat pump on plant side.

10.5.2 SUMMER/WINTER MODE COMMUTATION

This function is set by default on the digital input ID3 (terminals: ON/OFF-ON/OFF). To activate this function please set the parameter H76 to be 1 (H76=1).

You can manage remotely the operating mode in heating or in cooling of the heat pump.

In order to enable this function, you should enter into parameters PRG→PSS→PRG→ (insert the service password)→PRG→Par→PRG→CnF.

I/O Ports - Parameter	Value	Function
H76	1	Enables the remote summer/winter commutation function
Digital input (ID3 set by default)	3	Open Contact → Heat pump in heating mode. Closed Contact → The heat pump in cooling mode.

10.5.3 SANITARY MODE CALL FROM DIGITAL INPUT

If the domestic hot water mode operation is enabled and the parameter used as alternative of the temperature sensor, the activation of the domestic hot water operation can be performed through the opening/closing of a digital input of the unit. This function is recommended in the case of utilization of two or more minichillers in cascade configuration and linked through a hydronic connection to the same accumulation tank of domestic hot water; in this way the activation of the domestic hot water function will be selected through the sensor of the accumulation tank connected to the first unit, while the other units will be automatically enabled by a digital consent.

The system goes in domestic hot water mode when the digital input closes and quits this mode when the digital input opens.

In order to enable this function, you should enter into the page of parameters PRG→PSS→PRG→ (insert the service password) → PRG→Par→PRG→CnF.

I/O Ports - Parameter	Value	Function
H54	128	Digital inputs polarity
Digital input (activable on ID8)	28	Closed contact → Heat pump in DHW mode. Open contact → Heat pump in heating or cooling mode of the environment (plant system mode).

- In the case where a digital input is configured for DHW function call (instead of the sensor), the heat pump starts will be placed in DHW mode when the digital input is closed and exits from the DHW production when the digital input is open.
- The SAN setpoint of the heat pump is not considered, the management of such setpoint is entrusted to the designer of the plant, who must take into account the domestic hot water protection and the configuration of the whole system.

Note:

- You can reverse the polarity of the digital input, placing the maintainer (service) parameter to be H54 = 0.

Example of activation of the functions:

H10 = 1

H45 = 28 → Digital input [terminals: SAN – SAN]
Closed contact → Heat pump in sanitary mode.
Open contact → Heat pump in plant mode.

H54 = 128

H61 = 6(default) → In case of using a 3-way changeover valve with 3 contacts for power supply [terminals: NO1 – N – NC1]
→ In case of using a 3-way changeover valve with 2 contacts for power supply (with spring return), [terminals: NO1 – N]



10.6 REMOTE SENSOR FOR THE WATER TEMPERATURE OF THE PLANT CIRCUIT

In some configurations of systems (example: heat pump in parallel with a boiler on the same hydronic circuit and diverter valve of exclusion) it could be necessary to enable a plant temperature sensor to allow the on-board unit controller to correctly process the management.

In order to enable this function, please enter into the page of parameters **PRG**→**PSS**→**PRG** → (insert the service password) → **PRG** → **PAr** → **PRG** → **CnF**.

I/O Ports - Parameter	Value	Description
Analog input (activable on ST8)	41	Enablement of the plant circuit remote temperature sensor

The plant circuit remote sensor adjusts the heat pump temperature only during the startup period of the compressor(s), the shutdown is managed by the outlet temperature sensor of the heat pump. For more explanation herein below is reported an illustrating table regarding the operation of the system:

Operating mode	Enablement of the heat pump call
 Heating	Temperature measured by outlet sensor of the heat pump < setpoint Hea - b05 and Temperature measured by plant circuit remote sensor < water setpoint Hea - (b22 - b05)
 Cooling	Temperature measured by the outlet sensor of the heat pump > setpoint Coo + b05 and Temperature measured by plant circuit remote sensor > setpoint Coo + (b22 - b05)

Note: b05=1°C; b22=5°C. See paragraph 14.

10.7 AUXILIARY ELECTRIC HEATER

In some configurations of some plant systems, it could be necessary the use an auxiliary electric heater for the system and/or DHW sides.

To define the mode of using of the auxiliary electric heaters for plant system and DHW side, you must set the parameter “**r24**” as below.

- **r24=0** Auxiliary electric heaters not used;
- **r24=1** Utilization only of the auxiliary electric heater of the plant side;
- **r24=2** Utilization only of the auxiliary DHW electric heater;
- **r24=3** Utilization of both auxiliary electric heaters of plant side and of domestic (sanitary) hot water production.

10.7.1 PLANT CIRCUIT ELECTRIC HEATER

If the temperature of regulation remains below the **water setpoint in heating (Hea) - 0.5°C** for a period of time equal to **r12**, the auxiliary electric heater will be activated depending on the in joint or in substitution operation of the unit indicated in Paragraph 10.12.

The electric heater turns off after reaching the setpoint (taking into account of an eventual offset set with the parameters **r29** or **r30**).

If the temperature of regulation remains less than **water setpoint - r11(°C)** and the unit is blocked that is caused by an error-alarm, the electric heater will be activated. Then it will turn off when the lock-alarm is resolved.

In order to enable this function, you should enter into the page of parameters as follow **PRG**→**PSS**→**PRG** → (insert the service password) → **PRG** → **PAr** → **PRG** → **CnF / Fro**.

I/O Ports - Parameter	Value	Function
r10	1	Enablement of the function
r11	0.5°C (default)	Delta of the auxiliary electric heaters in heating operation
r12	10 minutes (default)	Activation delay of auxiliary heating element of the plant side
r24	1 or 3	Type of utilization of the electric heater
Undervoltage output (D03 by default)	22	Plant auxiliary electric heater

10.7.2 AUXILIARY ELECTRIC HEATER OF THE PLANT IN DEFROST CYCLE

During **defrost cycle** (see Paragraph 10.14), by setting **r21=1** (in addition to **r10=1** and **r24=1 or 3**) the electric heater of the plant system side will be activated if required (regulating temperature lower than the **water setpoint - r11 (°C)**), without waiting for the time defined by **r12**.

In order to enable this function, please enter into the page of parameters as follow **PRG**→**PSS**→**PRG** → (then insert the service password) → **PRG** → **PAr** → **PRG** → **Fro**.

10.7.3 ELECTRIC HEATER OF SANITARY WATER PRODUCTION

It is an additional energy resource for the sanitary water tank heating when the compressor is not able to reach the set temperature within a reasonable time.

If the production of sanitary hot water lasts for a period of time greater than **r16** (minutes) and the unit gets blocked due to an alarm intervention, the electric heater will be enabled. It turns off when the unit concludes the sanitary water production (taking into account also of any offset set by the parameters **r31** as described in the Paragraph 10.12.1.)

In order to enable this function, please enter into the page of parameters **PRG→PSS→PRG →** (insert the service password) **→ PRG → PAr → PRG → Fro.**

I/O Ports - Parameter	Value	Function
r15	1	Enablement of the function
r16	10 minutes (default)	Activation delay of the auxiliary DHW heating element
r24	2 o 3	Type of electric heaters utilization
Undervoltage output	26	Plant side auxiliary electric heater

Note: The DHW function must be active (see paragraph 10.3)

10.7.4A UNIQUE AUXILIARY ELECTRIC HEATER FOR BOTH PLANT SYSTEM/DHW PRODUCTION

By configuring the auxiliary electric heater for DHW production, you can use such declared electric heater, also as an auxiliary electric heater for the plant system by selecting the following setting **r15=2 and r24=3.**

When the auxiliary electric heater of the plant system is activated, the declared DHW electric heater will be activated allowing you to get one auxiliary electric heater for DHW production, plant system and defrosting operation.

In order to enable the function, you should enter into the page of parameters as follow: **PRG→PSS→PRG →** (then insert the service password) **→ PRG → PAr → PRG → Fro.**

10.8 SELECTION MODE OF AUXILIARY ELECTRIC HEATERS

It is possible to set the order priority of the activation of the of the plant system and of the DHW production sides auxiliary electric heaters as in the below configurations:

r14=0 (default), the electric heaters will be activated simultaneously if they are present;

r14=1, the electric heaters will be activated one excludes the other:

r20=0, the priority is for the plant (the sanitary heater will operate only if the thermoregulation for the heater of plant side is accomplished);

r20=1, the priority is for the sanitary (the electric heater of the plant system side will operate only if the thermoregulation of the sanitary heater is accomplished).

10.9 MANAGEMENT OF THE CIRCULATOR WITH ACTIVE ELECTRIC HEATER

It is possible to activate the circulator of the heat pump when the plant system and/or the DHW auxiliary electric heaters are active in the absence of compressors operations (for substitution, for alarm or for integration in band II or III).

For enabling this function, you should enter into the parameters as follow: press **PRG→PSS→PRG →** (then insert the service password) **→ PRG → PAr → PRG → Fro:**

– **r33 = 0:** The circulator of the heat pump will be activated upon request of the compressors or by the boiler.

– **r33 = 1:** The circulator of the heat pump will be activated if the plant circuit electric heater is active.

– **r33 = 2:** The circulator of the heat pump will be activated if the DHW electric heater is active.

– **r33 = 3:** The circulator of the heat pump will be activated if the plant system electric heater or if the DHW electric heater is active.

The circulator will stop operation after the post-pumping (**P02**).

10.10 BOILER ENABLEMENT

It is an additional resource that enables the boiler in integration or in substitution of the heat pump.

For enabling this function, you should enter into the parameters as follow: press **PRG→PSS→PRG→**(then insert the service password)**→PRG→PAr→PRG→CnF/Fro:**

Definition of the type of using of the auxiliary systems by setting the parameter **r23:**

- **r23=0** (default) boiler not used (priority of intervention is for electric heaters);
- **r23=1** boiler used just on plant side (priority of intervention is for electric heaters);
- **r23=2** boiler used just for DHW hot water (priority of intervention is for electric heaters);
- **r23=3** (default) boiler used for both DHW hot water and plant sides (priority of intervention is for electric heaters);
- **r23=4** boiler used only for plant side with priority (no intervention priority for electric heaters);
- **r23=5** boiler used only for DHW hot water with priority (no intervention priority for electric heaters);
- **r23=6** boiler used on both DHW and plant sides with priority (no intervention priority for electric heaters);

Settings of the parameter **r32** for boiler equipment:

- **r32 = 0**: boiler without a circulating pump with thermoregulation to be performed by the heat pump unit.
- **r32 = 1**: boiler equipped with independent circulating pump with thermoregulation to be performed by the heat pump unit.
- **r32 = 2**: boiler without circulating pump with independent thermoregulation.
- **r32 = 3**: boiler equipped with a circulating pump with independent thermoregulation.

I/O Ports - Parameter	Value	Function
r23	1/2/3/4/5/6	Type of boiler utilization
r32	1/2/3	Boiler Endowment
Under voltage output	29	Enablement of boiler

10.11 ACTIVATION OF AUXILIARY ELECTRIC HEATERS AND BOILER DURING THE JOINT AND IN SUBSTITUTION OPERATION TO THE COMPRESSOR OF THE HEAT PUMP

The available auxiliary systems for the joint operation or substitution operation are as below:

- **Boiler**
- **Plant auxiliary electric heater**
- **DHW (Sanitary) auxiliary electric heater**

Considering the heating and sanitary mode of operation, you have 4 types of operation:

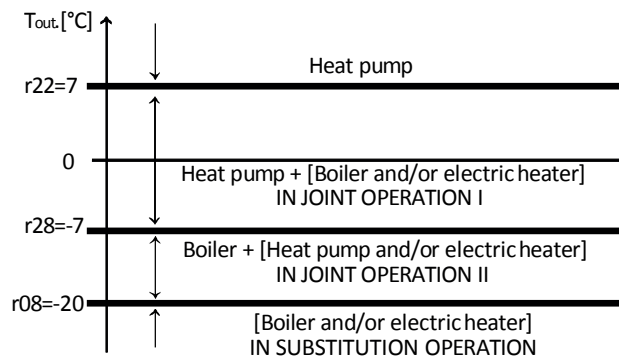

When changing the values of the parameters **r22**, **r28**, **r08**, you have to respect the following condition: **r22 ≥ r28 ≥ r08**.

You can remove the zone corresponding to the “in joint operation I” just by putting **r22=r28**; you can also remove the zone corresponding to the “in joint operation II” by putting **r28=r08**; and hence you can remove both “in joint operations I and II” just by setting the three parameters as the following configuration **r22=r28=r08**.

10.11.1 OPERATION IN HEAT PUMP MODE

Normal operation of the heat pump in which the electric heaters and-or the boiler will be activated only if the heat pump goes into error-alarm.

10.11.2 IN JOINT OPERATION (AREA I)

If the outdoor air temperature is included between **r22** and **r28**, the compressor operates in synergy with the auxiliary electric heaters during winter and domestic hot water mode.

In this operation area, the heat pump will start at the beginning and then the plant side auxiliary electric heaters will operate after a period of time given by **r12** (in minutes) and after **r16** (in minutes) the DHW auxiliary electric heaters will start operation.

The activation priorities are defined by the parameters **r14**, **r20**, **r23** and **r24**.

The operation becomes **normal** if the temperature increases above the value given by **r22 + 1,0°C**.

Note: In the joint operation, the temperature of the boiler is controlled by the water temperature remote sensor of the plant circuit (if enabled), particularly if the temperature measured by the remote sensor is less than the setpoint **Hea**, the boiler will be activated, and then will be deactivated when the measured temperature by the remote sensor is greater than setpoint **Hea**. The heat pump follows the activation logic described in paragraph 10.6.

The boiler will be managed by the outlet temperature sensor of the heat pump if the water plant circuit remote sensor is not enabled.

10.11.3 IN JOINT OPERATION (AREA II)

If the outdoor air temperature is included between **r28** and **r08**, the compressor will operate in synergy with the auxiliary electric heaters.

In this operation area, the devices will start operation in the following working order: at first the boiler will start the operation, then the heat pump and the plant circuit auxiliary electric heaters will start operation after a period of time given by **r12** (in minutes) and after **r16** (in minutes) the DHW auxiliary electric heaters will start operation.

The activation priorities are defined by the following parameters **r14**, **r20**, **r23** and **r24**.

The operation becomes **normal** if the temperature increases above the value of **r28+1,0°C**.

Note: In the joint operation, the temperature of the boiler is adjusted by the water temperature remote sensor of the plant circuit (if enabled), particularly if the temperature measured by this remote sensor is less than the setpoint **Hea**, the boiler will be

activated, and then will be deactivated when the measured temperature by the remote sensor is greater than setpoint **Hea**. The heat pump follows the activation logic described in paragraph 10.6.

The boiler will be managed by the outlet temperature sensor of the heat pump if the water plant circuit remote sensor is not active.

10.11.4 IN SUBSTITUTION OPERATION

If the outdoor air temperature decreases below **r08**, the compressor operation will be inhibited.

If the auxiliary system is composed of the plant circuit and/or the DHW electric heaters, they will be activated in substitution to the compressor with a duration defined by **r12** (minutes) for the plant circuit side and by **r16** (minutes) for the domestic hot water side.

During the substitution operation, instead it is not necessary to enable the auxiliary electric heaters with the parameter **r10** or **r15**, because the auxiliary electric heaters operate in substitution (and not as auxiliary heating systems) to the heat pump (therefore it is enough to select the type of utilization of the auxiliary electric heaters by setting only the parameter **r24**).

If the auxiliary system is a boiler with its proper circulator (**r32 = 1 or 3**).

The circulator of the heat pump will be off, the boiler will be enabled after **P01** (default 30 seconds).

Note: When the defrosting protection occurs on the water side, the utilization pump will be activated (or remains on).

If the in substitution auxiliary system is a boiler with its proper temperature control (**r32 = 2 or 3**).

The boiler will be enabled independently than thermoregulation of the heat pump.

If the in substitution auxiliary system is a boiler without circulator (**r32 = 0 or 2**).

The circulator of the heat pump will be active when the boiler is enabled.

The compressor will be enabled again if the temperature increases above the value of **r08+ r09** (°C) (by default r09=1,0 °C)

10.12 OPERATION AREA - ACTIVATION OF THE AUXILIARY ELECTRIC HEATER AND BOILER (Plant circuit water temperature sensor is not enabled)

The possible configurations of the parameters related to auxiliary heaters are listed below in the tables 1, 2, 3 and 4, that are divided by areas of operation (the columns of the items "**MODE**" and "**rx**" parameters indicate the operation mode and the possible values of the parameters for allowing the auxiliary electric heaters to act according to a predefined order of intervention, when the unit is running in a certain type of operation; several modes and values of the parameters can be alternatively selected and they are reported in the same cell separated by the symbol "/").

TABLE 1. NORMAL OPERATION IN HEAT PUMP MODE

N°	ORDER OF INTERVENTION OF HEATING SYSTEMS (when the set-point is not achieved and the unit is in alarm condition)	MODE	OPERATION	r10	r15	r12	r16	r23	r24
1	1) Auxiliary electric heater of plant	HEAT / HEAT+SAN	HEAT	1	0/1/2	/	/	0/2/5	1/3
2	1) Boiler	HEAT / HEAT+SAN	HEAT	0/1	0/1/2	/	/	1/3/4/6	0/2
3	1) Auxiliary electric heater of plant 2) After r12 minutes, Boiler	HEAT / HEAT+SAN	HEAT	1	0/1/2	Set up of minutes	/	1/3	1/3
4	1) Boiler 2) After r12 minutes, auxiliary electric heater of plant	HEAT / HEAT+SAN	HEAT	1	0/1/2	Set up of minutes	/	4/6	1/3
5	1) Auxiliary electric heater of sanitary	HEAT+SAN	SANITARY	0/1	1	/	/	0/1/4	2/3
6	1) Boiler	HEAT+SAN/ COOL+SAN	SANITARY	0/1	0/1/2	/	/	2/3/5/6	0/1
7	1) Auxiliary electric heater of sanitary 2) After r15 minutes, boiler	HEAT+SAN	SANITARY	0/1	1	/	Set up of minutes	2/3	2/3
8	1) Boiler 2) After r15 minutes, auxiliary electric heater of sanitary	HEAT+SAN	SANITARY	0/1	1	/	Set up of minutes	5/6	2/3
9	1) Auxiliary electric heater of Plant/sanitary	HEAT / HEAT+SAN	IN HEAT OR IN SANITARY	1	1	/	/	0	3
10	1) Boiler	HEAT / HEAT+SAN	IN HEAT OR IN SANITARY	0/1	0/1/2	/	/	3/6	0
11	1) Auxiliary electric heater of plant/sanitary 2) After r12 minutes, Boiler	HEAT / HEAT+SAN	IN HEAT OR IN SANITARY	1	1	Set up of minutes	Set up of minutes	3	3
12	1) Boiler 2) After r12 minutes, auxiliary electric heater of plant/sanitary	HEAT / HEAT+SAN	IN HEAT OR IN SANITARY	1	1	Set up of minutes	Set up of minutes	6	3

TABLE 2. JOINT OPERATION, AREA 1

N°	ORDER OF INTERVENTION OF HEATING SYSTEMS (when the set-point is not achieved)	MODE	OPERATION	r10	r15	r12	r16	r23	r24
1	1) Heat pump 2) After r12 minutes, auxiliary electric heater of plant	HEAT / HEAT+SAN	HEAT	1	0/1/2	Set up of minutes	/	0/2/5	1/3
2	1) Heat pump 2) After r12 minutes, boiler	HEAT / HEAT+SAN	HEAT	0/1	0/1/2	Set up of minutes	/	1/3/4/6	0/2
3	1) Heat pump 2) After r12 minutes, auxiliary electric heater of plant 3) After r12 minutes later, boiler	HEAT / HEAT+SAN	HEAT	1	0/1/2	Set up of minutes	/	1/3	1/3
4	1) Heat pump 2) After r12 minutes, boiler 3) After r12 minutes later, auxiliary electric heater of plant	HEAT / HEAT+SAN	HEAT	1	0/1/2	Set up of minutes	/	4/6	1/3
5	1) Heat pump 2) After r15 minutes, auxiliary electric heater of sanitary	HEAT+SAN	SANITARY	0/1	1	/	Set up of minutes	0/1/4	2/3
6	1) Heat pump 2) After r15 minutes, boiler	HEAT+SAN	SANITARY	0/1	0/1/2	/	Set up of minutes	2/3/5/6	0/1
7	1) Heat pump 2) After r15 minutes, auxiliary electric heater of sanitary 3) After r15 minutes later, boiler	HEAT+SAN	SANITARY	0/1	1	/	Set up of minutes	2/3	2/3
8	1) Heat pump 2) After r15 minutes, boiler 3) After r15 minutes later, auxiliary electric heater of sanitary	HEAT+SAN	SANITARY	0/1	1	/	Set up of minutes	5/6	2/3
9	1) Heat pump 2) After r12 minutes, auxiliary electric heater of plant/sanitary	HEAT / HEAT+SAN	HEAT OR IN SANITARY	1	1	Set up of minutes	Set up of minutes	0	3
10	1) Heat pump 2) After r12 minutes, boiler	HEAT / HEAT+SAN	IN HEAT OR IN SANITARY	0/1	0/1/2	Set up of minutes	Set up of minutes	3/6	0
11	1) Heat pump 2) After r12 minutes, auxiliary electric heater of plant/sanitary 3) After r12 minutes later, boiler	HEAT / HEAT+SAN	IN HEAT OR IN SANITARY	1	1	Set up of minutes	Set up of minutes	3	3
12	1) Heat pump 2) After r12 minutes, boiler 3) After r12 minutes later, auxiliary electric heater of plant/sanitary	HEAT / HEAT+SAN	IN HEAT OR IN SANITARY	1	1	Set up of minutes	Set up of minutes	6	3

TABLE 3. JOINT OPERATION, AREA 2

N°	ORDER OF INTERVENTION OF HEATING EQUIPMENTS (when the set-point is not achieved)	MODE	OPERATION	r10	r15	r12	r16	r23	r24
1	1) Boiler 2) After r12 minutes, heat pump	HEAT / HEAT+SAN	HEAT	0/1	0/1/2	Set up of minutes	/	1/3/4/6	0/2
2	1) Boiler 2) After r12 minutes, auxiliary electric heater of plant 3) After r12 minutes later, heat pump	HEAT / HEAT+SAN	HEAT	1	0/1/2	Set up of minutes	/	1/3	1/3
3	1) Boiler 2) After r12 minutes, heat pump 3) After r12 minutes later, auxiliary electric heater of plant	HEAT / HEAT+SAN	HEAT	1	0/1/2	Set up of minutes	/	4/6	1/3
4	1) Auxiliary electric heater of plant 2) After r12 minutes, heat pump	HEAT / HEAT+SAN	HEAT	1	0/1/2	Set up of minutes	/	0/2/5	1/3
5	1) Boiler 2) After r15 minutes, heat pump	HEAT+SAN	SANITARY	0/1	0/1/2	/	Set up of minutes	2/3/5/6	0/1

Controller for Chillers and inverter air / water heat pumps with axial fans

6	1) Boiler 2) After r15 minutes, auxiliary electric heater of sanitary 3) After r15 minutes later, heat pump	HEAT+SAN	SANITARY	0/1	1	/	Set up of minutes	2/3	2/3
7	1) Boiler 2) After r15 minutes, heat pump 3) After r15 minutes later, auxiliary electric heater of sanitary	HEAT+SAN	SANITARY	0/1	1	/	Set up of minutes	5/6	2/3
8	1) Auxiliary electric heater of sanitary 2) After r15 minutes, heat pump	HEAT+SAN/	SANITARY	0/1	1	/	Set up of minutes	0/1/4	2/3
9	1) Boiler 2) After r12 minutes, heat pump	HEAT / HEAT+SAN	IN HEAT OR IN SANITARY	1	1	Set up of minutes	Set up of minutes	3/6	0
10	1) Boiler 2) After r12 minutes, auxiliary electric heater of plant/sanitary 3) After r12 minutes later, heat pump	HEAT / HEAT+SAN	IN HEAT OR IN SANITARY	1	1	Set up of minutes	Set up of minutes	3	3
11	1) Boiler 2) After r12 minutes, heat pump 3) After r12 minutes later, auxiliary electric heater of plant/sanitary	HEAT / HEAT+SAN	IN HEAT OR IN SANITARY	1	1	Set up of minutes	Set up of minutes	6	3
12	1) Auxiliary electric heater of plant/sanitary 2) After r12 minutes, heat pump	HEAT / HEAT+SAN	IN HEAT OR IN SANITARY	1	1	Set up of minutes	Set up of minutes	0	3

TABLE 4. SUBSTITUTION OPERATION

N°	ORDER OF INTERVENTION OF HEATING SYSTEMS (when the set-point is not achieved)	MODE	OPERATION	r10	r15	r12	r16	r23	r24
1	1) Boiler 2) After r12 minutes, auxiliary electric heater of plant	HEAT / HEAT+SAN	HEAT	0/1	0/1/2	Set up of minutes	/	4/6	1/3
2	1) Auxiliary electric heater of plant 2) After r12 minutes, boiler	HEAT / HEAT+SAN	HEAT	0/1	0/1/2	Set up of minutes	/	1/3	1/3
3	1) Boiler 2) After r12 minutes, Auxiliary electric heater of sanitary	HEAT+SAN	SANITARY	0/1	0/1/2	/	Set up of minutes	5/6	2/3
4	1) Auxiliary electric heater of sanitary 2) After r12 minutes, boiler	HEAT+SAN	SANITARY	0/1	0/1/2	/	Set up of minutes	2/3	2/3
5	1) Boiler 2) After r12 minutes, auxiliary electric heater of plant/sanitary	HEAT / HEAT+SAN	IN HEAT OR IN SANITARY	0/1	0/1/2	Set up of minutes	Set up of minutes	6	3
6	1) Auxiliary electric heater of plant/sanitary 2) After r12 minutes, boiler	HEAT / HEAT+SAN	IN HEAT OR IN SANITARY	0/1	0/1/2	Set up of minutes	Set up of minutes	3	3
7	1) Boiler	HEAT / HEAT+SAN	HEAT	0/1	0/1/2	Set up of minutes	/	1/3/4/6	0/2
8	1) Auxiliary electric heater of plant	HEAT / HEAT+SAN	HEAT	0/1	0/1/2	Set up of minutes	/	0/2/5	1/3
9	1) Boiler	HEAT+SAN	SANITARY	0/1	0/1/2	/	Set up of minutes	2/3/5/6	0/1
10	1) Auxiliary electric heater of sanitary	HEAT+SAN	SANITARY	0/1	0/1/2	/	Set up of minutes	0/1/4	2/3
11	1) Boiler	HEAT / HEAT+SAN	IN HEAT OR IN SANITARY	0/1	0/1/2	Set up of minutes	Set up of minutes	3/6	0
12	1) Auxiliary electric heater of plant/sanitary	HEAT / HEAT+SAN	IN HEAT OR IN SANITARY	0/1	0/1/2	Set up of minutes	Set up of minutes	0	3

The below Table (5) shows the parameter to be set in order to enable the auxiliary electric heaters in "Summer and sanitary" mode (in this case, the only available auxiliary electric heater is the one of sanitary side and the subdivision between normal/joint/substitution operation is not valid).

TABLE 5. OPERATION IN COOL+SAN MODE (SANITARY MODE IS OPERATING)									
N°	ORDER OF INTERVENTION OF AUXILIARY ELECTRIC HEATERS - when the set point is not achieved after r16 minutes from the compressor startup or - when the set-point is not achieved and the unit is in alarm condition.	MODE	OPERATION	r10	r15	r12	r16	r23	r24

The below Table (6) shows the behavior of the auxiliary electric heaters of both sanitary and plant in all cases where the unit is operating.

TABLE 6. OPERATION OF AUXILIARY ELECTRIC HEATERS				
N°	MODE	OPERATION	AUXILIARY ELECTRIC HEATER OF PLANT	AUXILIARY ELECTRIC HEATER OF SANITARY
1	HEAT+SAN	HEAT	It works as indicated in the TABLES 1,2,3 and 4.	During "HEAT+SAN" operation, the sanitary thermoregulation by default will have priority over that of the plant side, so if the thermoregulation is required, the unit will start the "SANITARY" mode operation and the auxiliary electric heater of sanitary side behaves as described in the TABLES 1, 2, 3 and 4.
2	HEAT+SAN	SANITARY	<p>Only if the following 3 conditions are fulfilled:</p> <ul style="list-style-type: none"> - Output for auxiliary electric heater of plant side is configured; - r24=1/3; - the remote sensor of water plant temperature is installed and configured; <p>the auxiliary electric heater of the plant is active in the below cases:</p> <ul style="list-style-type: none"> - after r12 minutes from the beginning of its counting when activated previously in "HEAT" operation mode (see line N°1); - if not already activated its counting in the previous "HEAT" operation mode, after r12 minutes from the thermoregulation requirement. - In DHW (sanitary) mode, if the remote sensor is not set, the auxiliary electric heater of the plant will be disabled or its eventual counting will be stopped. - If the "on-off remote contact" turns to the open state, the auxiliary electric heater of the plant will be turned off. 	It works as indicated in the TABLE 1,2,3 and 4.
3	COOL+SAN	SANITARY	Not available.	It works as indicated in the TABLE 5.
4	COOL+SAN	COOL	Not available.	Not available.

10.12.1 AUXILIARY SYSTEMS OFFSET MANAGEMENT

During the joint operation or in substitution operation, for boiler and/or auxiliary electric heaters (depending on your resources and on the selected priorities) it is possible to determine a set-point in heating or sanitary greater than the one of the heat pump. This is achieved by setting a temperature offset for the set point:

- **r29**: Temperature offset for boiler and electric heaters of the plant for the first set point (**G02**);
- **r30**: Temperature offset for boiler and electric heaters of the plant for second set point (**G05**);
- **r31**: Temperature offset for boiler and sanitary electric heaters (**G03**).

In this way, the heat pump will stop when achieving the set-point (**G02, G03, G05**) and the temperature difference can be supplemented by the boiler and/or electric heaters according to the selected temperature offset.

10.13 SUMMER/WINTER OPERATION INDICATION

It is possible to set a digital output in order to indicate the operating mode of the unit, plant side.

The digital output is active during summer operation, while is not active during heating operation or when the unit is off.

During the DHW production and the defrosting, the output maintains the setting of the former season.

In order to enable such function, you should enter into the parameters as follow: press **PRG**→**PSS**→**PRG**→(then insert the service password)→**PRG**→**PAr**→**PRG**→**CnF**:

I/O Ports -Parameter	Value	Function
Under voltage output (activable on DO/OC)	31	Plant system season signalization

10.14 DEFROSTING CYCLE

The defrost cycle function is available only in heat pump mode and is used to prevent the frost formation on the surface of the air/air coil. The frost formation on the evaporator, which occurs more frequently at very low ambient temperatures, in addition to greatly decreasing the thermal efficiency of the unit, it can lead to the risk of damaging the unit itself. The adjustable parameters from the maintenance menu are: **d02**, for the pressure of initial defrosting process (bar) and **d08**, for setting of the minimum time interval between two consecutive defrosting processes (minutes), it is not recommended to change the default values of these.

You can configure a digital output which indicates that the defrosting is in progress.

In order to enable this function, you should enter into the parameters as follow: press **PRG**→**PSS**→**PRG** → (then insert the service password) → **PRG** → **PAr** → **PRG** → **CnF**

I/O Ports - Parameter	Value	Function
Under voltage output (activable on DO/OC)	21	Indicates the occurring defrost cycle

10.15 COMPRESSOR CRANKCASE HEATER

The crankcase heater operates when the compressor remains off for at least 30 minutes and if the discharge temperature is below 20°C (with hysteresis of 2.0°C). When the compressor restarts, the crankcase heater will stop.

10.16 MANAGEMENT OF THE SECONDARY CIRCULATOR/RELAUNCHING PUMP (with room thermostat)

It allows the management of a secondary or relaunching circulator for serving the plant system

A normally closed (NC) room thermostat must be properly configured.

Open contact thermostat → The secondary circulator will be activated;

Closed contact thermostat → The secondary circulator is off with a delay given by P02 (post-pumping).

In order to enable such function, please enter into the parameters **PRG**→**PSS**→**PRG**→(insert the service password)→**PRG**→**PAr**→**PRG**→**CnF**.

I/O Ports - Parameter	Value	Function
Digital input (Activable on ID3 / ID7 / ID8)	19	Thermostat call
Under voltage output (Activable on DO/OC)	43	Secondary circulator

The temperature control of the heat pump is independent than the call of the thermostat.

With heat pump in Off mode, the relaunching circulator will be switched off independently of the thermostat call.

Example of activation function:

H40 = 19 → Digital input [terminals: S/W – S/W]

H58 = 43 → Secondary circulator power supply [terminals: AEH - AEHN]

10.17 Maximum Hz

This function is disabled by default.

To activate the **Maximum Hz** function, you should set the parameter **L02** to the value **L02=1**, the cooling and heating capacities will increase with 10% (depending on the heat pump model and working conditions). You can also for define a special operating mode by setting the parameter “**L03**” to a particular value as indicated in the below table.

In order to enable this function, you should enter into the parameters as follow: press **PRG**→**PSS**→**PRG** → (then insert the service password) → **PRG** → **PAr** → **PRG** → **LbH**

I/O Ports - Parameter	Value	Function
L02	1	Activating the function
L03	1	Activating the function in cooling mode.
	2	Activating the function in heating mode.
	3	Activating the function in DHW mode.
	4	Activating the function in cooling and DHW mode.
	5	Activating the function in mheating and DHW mode.
	6	Activating the function in cooling and heating mode.
	7 (default)	Active function for all modes.

Note that the value of the parameter **L03** has no effect if **L02** is equal to zero.

For more information, please contact our office.

10.18 DOUBLE SET-POINT (without remote control Hi-T)

The double set-point function introduces a second working set-point of the plant side (in both cooling and heating modes).

You can configure in the user terminal block a digital input which provide a consent for the transition from the first to the second set-point and vice versa or which connect the humidistat that is part of the double set-point kit (just in case you do not have the touch-screen remote control Hi-T).

10.18.1 CONTROL SETTINGS

In order to enable such function, you should enter into the parameters as follow: press **PRG**→**PSS**→**PRG** → (then insert the service password) → **PRG** → **PAr** → **PRG** → **CnF**:

I/O Ports- Parameter	Value	Function
H82	1	Disenabled function
	2	Activating the double setpoint function in summer period
	3	Activating the double setpoint function in winter period
	4	Activating the double setpoint function in summer and winter periods
Digital input (Activable on ID3 / ID7 / ID8)	26	Call of double set-point
Under voltage output (Activable by default on OC2)	25	3-way valve for radiant panels

10.18.2 NOTES FOR INSTALLATION

Humidistat (double set-point kit)

The relay of the humidistat must be connected as NC.

Two cases can be distinguished:

dehumidification is not required (activation of dual set-point)

When the relay is de-energized, the water will be diverted to the floor plant (according to set-point)

dehumidification is required (deactivation of dual set-point):

When the relay is energized, the water will be diverted to the fan-coil units (first set point)

Relay (double set-point kit)

Example of function activation:

H82 = 4

H19 = 0

H44 = 26 → Digital input [terminals: SE – SE]

H61 = 25 → In case of implementing a changeover 3-way valve with 3 contacts for power supply [terminals NO1 – N - NC1]

In case of implementing a changeover 3-way valve with 2 contacts for power supply (with spring return), [terminals NO1 – N]

However, it is recommended to use an external relay, included in the dual set-point kit, to allow the connection with higher loads (up to 8A resistive, 1.6A inductive) and at the same time separate the lines of the power supply of the minichiller, 3-way valve and fan coils (in this case it is necessary to provide appropriate protection to the power supply line of the fan coil).

In this second case, the relay must be installed on board machine in the DIN bar of the user’s terminal block, connecting the power supply for V3 models to **N2-NC2** terminals.

The 3-way valve with 2 or 3 contacts for power supply connection

The 3-way valve is applied to divert the water flow between floor plant and fan coil units.

In the case of a 3-way valve with 2 contacts for power supply (with return spring), when the 3-way valve is not activated, the outlet of the valve that is opened must be connected to the floor plant.

10.18.3 HUMIDISTAT OPERATION

By reading the internal sensor of temperature and humidity, the dew point temperature will be calculated.

- Tint: room temperature detected by the indoor unit temp. sensor (°C)
- Tr: calculated temperature of the dew point (°C)
- odr: adjustment offset (°C)
- Hy: adjustment hysteresis (°C)
- tAr: adjustment time (min.)
- Activation time relay: 0÷100% of tAr.

The temperature measured from the internal sensor to the controller will be compared with the dew point (evaluated at the last moment of tAr) added to the parameters odr and Hy:

- If $Tr < Tint < Tr + odr \rightarrow$ the relay is activated for all the next tAr time.
- If $Tr + odr < Tint < Tr + odr + Hy \rightarrow$ The relay is activated for the value in % of the detected on the pump.
- If $e Tint > Tr + odr + Hy \rightarrow$ the relay is activated for all the next tAr time.

The parameters tAr, odr and Hy are set in the factory and can be changed.

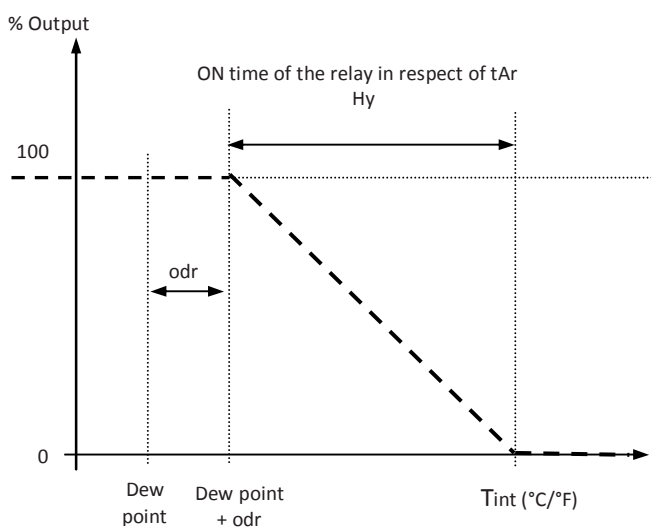

10.18.4 ADJUSTABLE SET-POINT

Set-point type	Setpoint (summer/winter)	Summer	Winter
First set-point (°C)	Coo/Hea	7 (5÷18)	45 (35÷57)
Second set-point (°C)	Co2/He2	18 (7÷23)	35 (25÷45)

Use SET button on the control panel of the machine to adjust the setpoints.

The second set-point is greater than the first set-point in the summer and lower in winter:

in the summer: $T2 \geq T$

in the winter: $T2 \leq T$

10.18.5 COMMUTATION

The commutation sequence from normal set-point to the second setpoint:

- 1) Modification of operating set-point.
 - 2a) in the summer: Commutation of the 3-way valve only when the second set-point -5°C is reached.
 - 2b) in the winter: commutation of the 3-way valve only when the second set-point +5°C is reached.
- (At any case after 5 min from setpoints modification, the commutation of the valve will be carried out)

The commutation sequence from second set-point to the normal setpoint:

- 1) Commutation of the 3-way valve
- 2) Modification of the operating setpoint after a lap of time equal to the required time for opening of the 3-way valve. (default **b04=30s** from maintainer menu)



WARNING: When using a 3-way valve for dual setpoint, if the valve has 3 contacts for the power supply and in the case of external relay connection, the valve will also remain energized when the minichiller is in OFF state or when is turned off by the internal switch. For safety reasons we strongly recommend to turn OFF the external breaker of the electrical power when the unit should be maintained.

10.18.6 HUMIDISTAT WIRING

Carry out the following connections between the humidistat and the terminal block of the minichiller unit:

- Connect POWER SUPPLY to 12V+ and 12V-.
- Connect RELAY-C/NC to the two terminals SE.

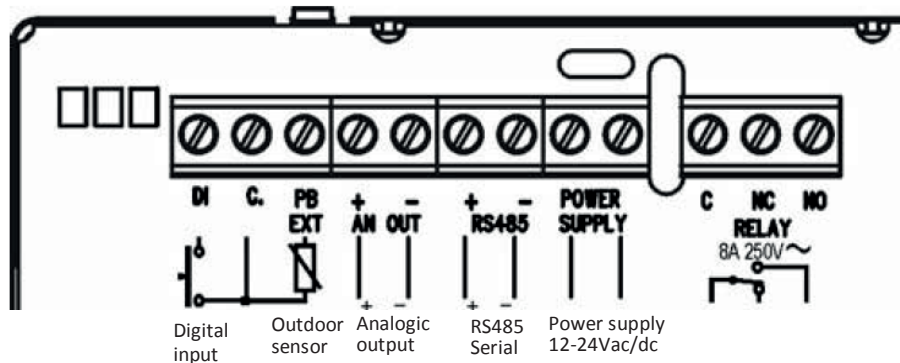

11 AVAILABLE FUNCTIONS WITH Hi-T ACCESSORY

The Hi-T is a touch screen remote control panel for centralized management of chiller/heat pump, it equipped with humidity and temperature sensors for environment analysis and for the management of the double setpoint for radiant floor systems equipped a dehumidification system.

This remote control panel is an intuitive interface very simple for utilization; the functions are all easy to set through the use of synoptic of immediate understanding.

The functions accessible through the touch screen Control Panel are listed below:

- Remote management
- Management of a network, up to 7 heat pumps;
- Zone thermostat
- Screed function;
- Legionella disinfection;
- Double set-point and dehumidification;
- Dew point control
- Climatic compensation
- Relaunching circulator Management
- Management of a unique network pump
- Faults diagnostic system

For further information, please see the user's-installer's manual, or contact our offices.

12 AVAILABLE FUNCTIONS WITH KIE MODULE (optional)

The KIE module is an optional kit, with the installation of the (SL2) controller which allows the management of the following functions:

1. As alternative to the plant system management "Gi" module.
2. DHW rapid preparer management and DHW recirculation.
3. Mixing valve management plant system side in both heating and cooling;
4. Solar-thermal integration management.

For more details, please check the manual of the KIE module.

13 HANDBOOK FOR CONFIGURATIONS OF INSTALLATION

If you need more information about the possible configurations, there is a handbook, which is a technical book containing a series of recommended drawings of plants that have been highlighted regarding the installation configuration of our high efficiency heat pumps. The "Handbook" aims also the task of showing the symbiotic potential with some of our items in the catalog.

You can contact our office for asking the handbook.

14 TABLES OF CONFIGURATIONS ALLOWED TO USER AND INSTALLER V4

Following the below table, the permitted configurations cannot be selected simultaneously.

Values different than the default can ensure the proper operation of the unit, in case of doubt about the value to be set contact please our office.

Note:

- (*) Programmable setpoint if the DHW function is activated
- (**) Programmable setpoint if the optional module KIE is present
- (***) Don't change if "KA" kit is present

Parameter	Description	Unit	Default	Range	Visibility	Admitted configuration		Note
						Value	Description	
Coo	First setpoint in cooling mode	°C	7.0	H03÷Co2	U			
Hea	First setpoint in heating mode	°C	45.0	He2÷H01	U			
*San	Domestic water temperature setpoint	°C	48.0	H02÷H01	U			
Co2	Second setpoint in cooling mode	°C	18.0	Coo÷H03	U			
He2	Second setpoint in heating mode	°C	35.0	H02÷Hea	U			
**rCO	Mixing valve summer setpoint	°C	15.0	-50.0÷80.0	U			
**rHE	Mixing valve winter setpoint	°C	30.0	-50.0÷80.0	U			
**ACS	Setpoint instantaneous production of DHW	°C	0.0	0.0÷80.0	U			Adjustable parameters with the KIE accessory
H01	Maximum setpoint in heating mode	°C	58.0	-50.0÷80.0	I			It is not recommended to modify such value
H02	Minimum setpoint in heating mode	°C	25.0	-50.0÷80.0	I			It is not recommended to modify such value
H03	Maximum setpoint in cooling mode	°C	23.0	-50.0÷80.0	I			It is not recommended to modify such value
H04	Minimum setpoint in cooling mode	°C	5.0	-50.0÷80.0	I			
H10	Enabling of the sanitary function	/	0	0÷2	I	0	Disabled function	See paragraph 10.3
						1	Active function in heating and cooling mode The remote on-off function doesn't disable the DHW production.	
						2	Active function in heating mode and cooling mode The remote on-off function disables the DHW production.	
						3	Active function in heating mode The remote on-off function doesn't disable the DHW production.	
						4	Active function in heating mode	
						5	Active function in cooling mode The remote on-off function doesn't disable the DHW production.	
H19	ST8 analogic input configuration	/	0	0÷49	I	0	Input not assigned	SE-SE terminals Serviceable input if you set H44=0 (See paragraph 10.6)
						41	water temperature remote sensor	
						0	Input not assigned	
						6	DHW temperature	
						0	input not assigned	
						40	0-10V input	
H20	ST9 analogic input configuration	/	0	0÷49	I	0	Input not assigned	SE-SE terminals Serviceable input if you set H45=0 (See paragraph 10.3)
						0	input not assigned	
H21	ST10 analogic input configuration	/	0	0÷49	I	0	input not assigned	Terminals: 0-10V-0-10V
						2	remote ON/OFF	
H39	D12 digital input configuration	/	2	0÷30	I	0	input not assigned	Terminals: ON/OFF See paragraph 10.3
						2	remote ON/OFF	
H40	D13 digital input configuration	/	3	0÷30	I	0	input not assigned	Terminals S/W terminals To enable the function you should set H76=1 (see 10.5.2)
						3	Remote Summer-Winter mode switching	
H44	D17 digital configuration	/	26	0÷30	I	0	input not assigned	Terminals: SE-SE Serviceable input in exclusion of ST8 (if you should use it, set H19=0)
						26	second set-point humidistat	
H45	D18 digital configuration	/	0	0÷30	I	19	Thermostat call	Terminals: SAN-SAN Serviceable input in exclusion of ST9 (if you should use it, set H20=0) (See paragraph 10.5.3)
						0	Input not assigned (Normally open)	
H54	Digital input polarity	/	0	0÷255	I	19	DHW Thermostat call from digital input	
						28	Thermostat call	
						0	Digital inputs polarity = NO	
						64	"Normally closed" D17 digital input	
H58	DO3 undervoltage digital output configuration	/	22	0÷44	I	128	"Normally closed" D18 digital input	AEHN-AEH terminals to connect to the coil of the contactor (contact NO 230Vac)
						0	input not assigned	
						21	Signalization of defrost cycle in progress	
						22	auxiliary electric heater of the plant	
						24	alarm	

***H59	DO4 Undervoltage digital output configuration	/	0	0÷44	I	26	DHW auxiliary electric heater	Terminals: DO4N-DO4 It is recommended to install an external relay in order to reduce the total power consumption of the unit.
						29	Boiler enablement	
						31	Plant season signalization	
						43	Plant secondary pump	
						0	Input not assigned	
						21	Signalization of defrost cycle in progress	
						22	Auxiliary electric heater of the plant	
						24	Alarm	
						26	Auxiliary electric heater of DHW	
						29	Boiler enablement	
						31	Plant season signalization	
						43	Plant secondary pump	
						0	Input not assigned	
						21	Signalization of defrost cycle in progress	
22	Auxiliary electric heater of the plant system							
24	Alarm							
26	Auxiliary electric heater of DHW							
29	Boiler enablement							
31	Plant season signalization							
43	Plant secondary pump							
0	Input not assigned							
21	Signalization of defrost cycle in progress							
22	Auxiliary electric heater of the plant system							
24	Alarm							
26	DHW auxiliary electric heater							
29	Boiler enablement							
31	Plant season signalization							
43	Plant secondary pump							
1	DHW valve							
0	Input not assigned							
21	Signalization of defrost cycle in progress							
22	Auxiliary electric heater of the plant							
24	Alarm							
26 = 26	Sanitary auxiliary electric heater							
29	Boiler enablement							
31	Plant season signalization							
43	Plant secondary pump							
25	Double setpoint valve							
0	Disabled function							
1	Enabled function							
In case of several minichillers in cascade you have to assign different addresses for each control.								
H76	Remote operating mode selection (summer/winter)	/	0	0÷1	I	0	Disabled function	Terminals: NC2, N, NO2 Enabled function if H40=3. See paragraph 10.6.2
						1	Enabled function	
						In case of several minichillers in cascade you have to assign different addresses for each control.		
H79	Serial address	/	1	1÷200	I	0	0 = Disabled function	
						1	Classic mode	
						2	Cooling double setpoint	
H82	Enabling double setpoint	/	0	0÷4	I	3	Heating double setpoint	See paragraph 10.18

Controller for Chillers and inverter air / water heat pumps with axial fans

Parameter	Description	Unit	Value	Type	4		Notes
					0	1	
H83	Enabling heating always diverted towards the sanitary mode	/	0	I	Cooling and heating double setpoint		
A03	Bypass flow from pump activation	sec	10	I	0	1	The DHW operation should be active
A08	Antifreeze alarm activation set	°C	3	I	-127÷127		The alarm is not active for duration of A03 from the activation of the pump. It is not recommended to modify such value
A16	Low pressure setting in cooling mode	Bar	Depending on the model	I	-50.0÷80.0		It is not recommended to modify such value
b01	Band in cooling mode	°C	1.0	I	0÷10.0		It is not recommended to modify such value
b02	Band in heating mode	°C	1.0	I	0÷25.5		It is not recommended to modify such value
b03	Differential in DHW (sanitary) mode	°C	1.0	I	0÷25.5		It is not recommended to modify such value
b04	Commutation time of the radiant panels valve	sec	30	I	0÷600		
b05	Hysteresis cut-off of the compressor in cooling and in heating	°C	1	I	0.0÷25.5		Recommended values between 1 & 1.5 Other values different than the default may ensure optimal operation of unit
b06	Transient sanitary output in heating	sec	45	I	0÷25.5		
b07	PI regulator integral time	sec	150	I	0÷25.5		It is recommended to use the 60 sec for systems with limited water flow, while for systems with a high water flow use the value 180 sec. Other different values can ensure the optimal operation of unit
b08	Enabling of dynamic set	/	0	I	0÷1		
b09	Cooling maximum offset	°C	3.0	I	-50.0÷80.0		
b10	Heating maximum offset	°C	-3.0	I	-50.0÷80.0		
b11	Outdoor air setpoint in cooling operation	°C	25	I	-127÷127		
b12	Outdoor air setpoint in heating operation	°C	15	I	-127÷127		
b13	Temperature differential in cooling	°C	-10.0	I	-50.0÷80.0		
b14	Temperature differential in heating	°C	10.0	I	-50.0÷80.0		
b15	Set-point regulation band by analog input 0-10V	/	5.0	I	0.0÷10.0		
b20	Enabling of the inputs 0-10V/ratiometric	/	0	I	0	1	0-1.0V input Ratiometric input
b22	Thermoregulation cut-off Hysteresis plant sensor	°C	5	I	0.0÷25.5		See paragraph 10.6
F08	Set of the pressure at the minimum fan speed in cooling mode	Bar	Depending on the model	I	-50.0÷80.0		
F09	Proportional band for fan motor modulation in cooling mode	Bar	Depending on the model	I	0.0÷25.5		
F10	Fan cut-off delta	Bar	Depending on the model	I	0.0÷25.5		
F11	Cut-off hysteresis	Bar	Depending on the model	I	0.0÷25.5		
F12	bypass cut-off time	Sec.	Depending on the model	I	0÷25.5		
F14	Setting of the pressure at the maximum fan speed in cooling mode	Bar	Depending on the model	I	-50.0÷80.0		
F17	Setting of the pressure at the minimum fan speed in heating mode	Bar	Depending on the model	I	-50.0÷80.0		
F18	Proportional band for fan motor modulation in heating mode	Bar	Depending on the model	I	0.0÷25.5		
F20	Setting of the pressure at the maximum fan speed in heating mode	Bar	Depending on the model	I	-50.0÷80.0		
F31	Setting of forced fan stop for low outside temperatures	°C	-127	I	-127÷127		

Controller for Chillers and inverter air / water heat pumps with axial fans

F32	Maximum fan speed reduction % in cooling mode	%	Depending on the model	0 ÷100	I				
F33	Maximum fan speed reduction % in heating mode	%	Depending on the model	0 ÷100	I				
P01	Pump ON compressor ON time delay	sec	30	0÷255	I				
P02	Pump OFF compressor OFF time delay	min	1.0	0÷25.5	I				
P03	Pump operation mode	/	1	0÷1	I		0	Continuous operation	The pump is always ON if the antifreeze electric heaters are ON (see chap. 8)
P04	Adjustment of the pump in antigel	°C	5	-15÷15	I		1	Thermoregulation operation	
P05	Hysteresis for the pump in antigel mode	°C	2.0	0.0÷15.0	I				
P07	Maximum speed of modulating pump	%	Depending on the model	0÷100	I				
P08	Minimum speed of modulating pump	%	Depending on the model	0÷100	I				
P09	Set Delta T[°C] T inlet water/outlet of modulating pump	°C	5	0÷15	I				
P10	Delta T[°C] modulating pump	°C	5.0	0.0÷15.0	I				
P16	Time between 2 activations of the pump in periodic mode	min	0	0÷600	I				
P17	Operating time of the pump in periodic mode	sec	0	0÷255	I		0	Periodic mode is disabled	
r02	Set point of anti-freeze heater in heating mode	°C	4	3÷6	I				
r03	Set point of anti-freeze heater in cooling mode	°C	4	3÷6	I				
r06	Anti-freeze electric heater differential	°C	2.0	0.0÷25.5	I				
r08	Upper limit during substitution operation	°C	-20	-16÷50	I			Respect the condition r22 ≥ r28 ≥ r08	
r10	Enabling of the auxiliary electric heater of the plant	/	0	0÷1	I		0	Disabled function	
r11	Auxiliary electric heater differential of the plant	°C	0.5	0.0÷25.5	I		1	Enabled function	
r12	Time delay of activation of the plant auxiliary electric heater	min	10	0÷255	I				
r14	Exclusive electric heaters operation	/	0	0÷1	I		0	Electric heaters can be activated simultaneously	
r15	Enabling of auxiliary electric heaters of sanitary circuit	/	0	0÷2	I		1	Heaters can be activated exclusively	
r16	Time delay of activation of the auxiliary electric heaters of sanitary circuit	/	15	0÷255	I		0	Disabled function	
r19	Activation period of drain pan heaters from last defrost operation	min	10	0÷255	I		1	Enabled function	
r20	Electric heaters utilization priority	/	1	0÷1	I		2	Operation of the plant auxiliary heaters only if H83=1	
r21	Enabling the mitigation to plant side with heaters in defrost	/	0	0÷1	I		0	Disabled function	
r22	Upper Limit Function. Joint operation upper limit Band I	/	7	-16÷50	I		1	Enabled function	Respect the condition r22 ≥ r28 ≥ r08

Controller for Chillers and inverter air / water heat pumps with axial fans

r23	Types of utilization of the boiler	/	6	0÷6	I	0	Boiler OFF	See paragraph 10.10
						1	Use of boiler in plant integration (Priority of intervention goes to the electric heaters)	
						2	Use of boiler in DHW integration (Priority of intervention goes to the electric heaters)	
						3	Use of boiler in plant and DHW integrations (Priority of intervention goes to the electric heaters)	
						4	Use of boiler in plant integration (Priority of intervention goes to the boiler)	
						5	Use of boiler in DHW integration (Priority of intervention goes to the boiler)	
						6	Use of boiler in plant and DHW integrations (Priority of intervention goes to the boiler)	
r24	Types of utilization of the auxiliary electric heaters	/	3	0÷3	I	0	Auxiliary heaters not used	See paragraph 10.7
						1	Auxiliary electric heater	
						2	Auxiliary electric heater of DHW	
						3	Auxiliary electric heaters of sanitary and plant circuits	
r25	Disinfection anti-legionel setpoint	°C	80	0÷100	I		Activable and programmable function by mean of the remote control panel accessory HI-T .	
r26	Disinfection duration	min	12	0÷255	I			
r27	Heat pump operating mode setpoint for disinfection	°C	48.0	-50.0÷80.0	I			
r28	Upper limit for joint operation area II	°C	-7	-16÷50	I	Respect the condition r22 ≥ r28 ≥ r08		
r29	Temperature offset for boiler and heaters of the plant, first setpoint (HEA)	°C	0	0÷100	I			
r30	Temperature offset for boiler and heaters of the plant second setpoint (HEA2)	°C	0	0÷100	I			
r31	Temperature offset for boiler and sanitary circuit heaters (SAN)	°C	0	0÷100	I	See paragraph 10.12.1		
r32	Equipment with boiler	/	1	0÷3	I	0	Circulator active under compressors call for eventual boiler request (see r32)	See paragraph 10.10
						1	The circulator is active if the plant electric heater is active	
						2	The circulator is active if the DHW electric heater is active	
						3	The circulator is active if the plant or DHW electric heater is active	
r33	Pump management with active electric heaters	/	0	0÷4	I	0	Circulator active under compressors call for eventual boiler request (see r32)	See paragraph 10.9
						1	The circulator is active if the plant electric heater is active	
						2	The circulator is active if the DHW electric heater is active	
						3	Circulator is active if the plant or the DHW electric heater is active	
d02	Pressure of initial defrost	bar	5,4	-50,0÷80,0	I		Parameters can be enabled only if configured by default After a time equal to d08, the circuit starts defrosting process.	
d08	Time between two consecutive defrosting cycles	min	30	0÷255	I			
n06	Compressors locking mode for installer	/	0	0÷1	I			
L02	User enablement for maximum Hz	/	0	0÷1	U			
L03	Activate Max. Hz	/	7	0÷7	U	0	Disabled function	See paragraph 10.17
						1	Enabled function	
						0	Disabled function	
						1	Other values different from the default one can ensure optimal operation of the unit	
						2	Active function in cooling mode	
						3	Active function in heating mode	
						4	Active function in cooling and in DHW mode	
5	Active function in heating and in DHW mode							
6	Active function in cooling and heating mode							
7	Active function in all operating modes							

15 ALARMS

15.1 WATER FLOW SWITCH ALARM E06

The water side flow switch is already installed inside the unit and DOES NOT HAVE to be tampered with or by-passed in any way. The flow switch is by-passed for 10 seconds after the unit's start up. The alarm signal occurs after 5 seconds of the error appearance (lack of water flow, air inside the circuit, etc.). The alarm will automatically reset itself for the first two times and it will be deactivated after 5 seconds. If the alarm happens more than 3 times per hour, you should manually reset it.

The alarm is not active in the below situations:

- For duration of A03 (10 seconds) from the pump startup.
- During the domestic hot water production
- During the purging cycle of the system.

15.2 HIGH TEMPERATURE E18

The alarm will be activated when the outlet water temperature sensor becomes higher than 65°C for 50 seconds. It turns off when the water outlet temperature decreases below 62°C.

15.3 ANTI-FREEZING E05

The alarm will be activated when the outlet water temperature sensor is less than A08 (13°C). It turns off when the temperature becomes higher than +6°C. The alarm will be bypassed for 120 seconds from the turning on of the unit in heating mode.

15.4 SENSORS ALARM E611÷E691

The alarm will be activated in the case of a short or open circuit of any connected and enabled sensor.

The alarm will be activated also when the temperature becomes higher than the sensors' upper limit of 100°C or less than the lower limit of -50°C.

A temperature sensor configured as a sensor for sanitary mode, does not lead to alarm if the sanitary mode is not enabled.

15.5 TIMEOUT INVERTER E801

Supposing the controller does not communicate with the driver board of the compressor, the time out alarm will be activated in order to prevent a system's control loss.

15.6 INVERTER [E851÷E971]

The inverter has its own alarm list.

15.7 REMOTE ON/OFF E00

In this case the unit is controlled from a remote digital input.

15.8 HIGH PRESSURE E01

If the on board pressure transducer detects a pressure higher than 41 bar, the alarm will be activated.

In this case the compressor will stop immediately. The alarm will reset when the pressure decreases under 37bar.

If the alarm occurs more than 3 times per hour, the alarm becomes at manual reset.

15.9 HIGH PRESSURE FLOW SWITCH (IN SERIES WITH THE COMPRESSOR OUTLET PROBE) E641

If the pressure switch on the machine detects a pressure higher than 44 bar the alarm will be active.

In this case, the compressor is immediately stopped. The alarm resets when the pressure drops below 31bar.

If the number of alarm interventions in one-hour is equal to 3 times, it will become a manual reset.

15.10 LOW PRESSURE E02

If the pressure transducer installed on the unit detects a pressure lower than the value set by the controller, the alarm will be ON. The alarm is not active 60 seconds after the startup of the compressor.

When the alarm is ON, the compressors in the circuit and the outdoor fans will stop operation.

If the number of alarm interventions in one-hour is equal to 3 times, it becomes a manual reset.

Note: After turning off the minichiller unit, all its own alarms will reset and the number counting the interventions of the relative alarms will reset also.

15.11 [E08] RIVER LIMITATION

If the compressor does not reach the ramp speed value within 30 minutes, the alarm becomes active and the compressor will stop for safety.

The alarm becomes manual rest if it occurs for 3 times in one hour.

15.12 POWER FAILURE

After power supply reset:

1. The system comes back to the previous state before the power failure.
2. If the system is defrosting, this mode will be cancelled after power supply reset.
3. All the running timings will be cleared and reset again.

15.13 USER BLOCK ALARM LIST

Error code	Error description	Compressor	Circulator	Fan	Electric heaters
E00	Remote off [Indoor unit]	OFF	OFF	OFF	OFF
E01	High pressure	OFF	OFF		
E02	Low pressure	OFF		OFF	
E05	Anti-freezing alarm	OFF	ON	OFF	ON
E06	Flow switch	OFF	OFF	OFF	OFF
E08	Compressors stop operation for lack of lubricant	OFF			
E18	High temperature	OFF			OFF
E611	Inlet water temperature sensor	OFF	OFF	OFF	OFF
E621	Outlet water temperature sensor	OFF	OFF	OFF	OFF
E631	Compressor inlet temperature sensor	OFF	OFF	OFF	OFF
E641	Compressor outlet temperature sensor + HP switch	OFF	OFF	OFF	OFF
E651	High pressure transducer	OFF	OFF	OFF	OFF
E661	Low pressure transducer	OFF	OFF	OFF	OFF
E671	Outdoor temperature sensor for climatic region	OFF	OFF	OFF	OFF
E681	SE/SE sensor (if enabled)	OFF	OFF	OFF	OFF
E691	SAN/SAN sensor (if enabled)	OFF	OFF	OFF	OFF
E801	Timeout inverter	OFF		OFF	
E851	Inverter hardware error	OFF		OFF	
E861	Electric current of compressor is too high	OFF		OFF	
E871	Inverter heat sink high temperature	OFF		OFF	
E881	Power supply voltage of the of inverter is out of limits	OFF		OFF	
*E891	Compressor not connected to the driver	OFF		OFF	
*E901	Compressor model error	OFF		OFF	
*E911	Driver overload protection	OFF		OFF	
*E921	Diver overcurrent	OFF		OFF	
*E931	Driver communication fault	OFF		OFF	
*E941	PFC driver	OFF		OFF	
*E951	Driver temperature sensor fault	OFF		OFF	
*E961	Driver fault	OFF		OFF	
*E971	EEPROM driver	OFF		OFF	

(*) Available for the model CHIP-M/V4 14

