

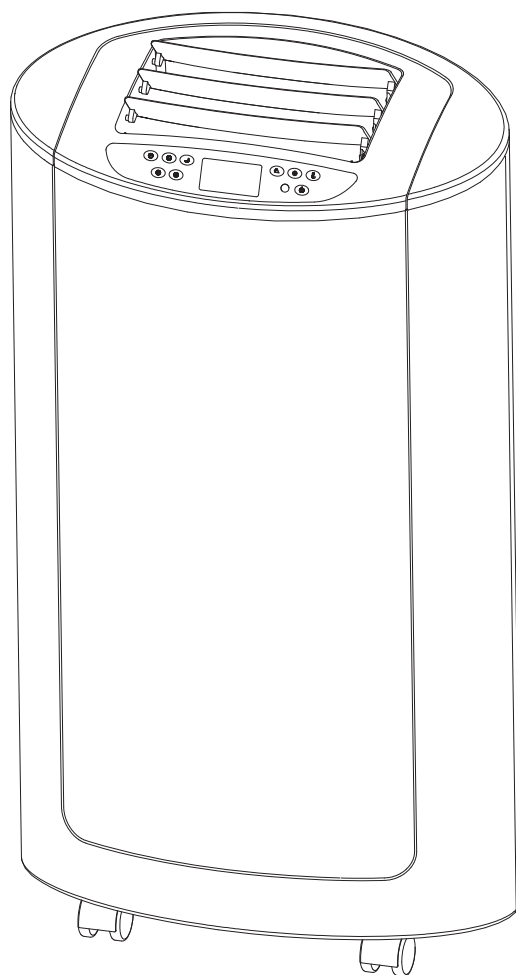

PORTABLE AIR-CONDITIONER
USER MANUAL
AIRCO12000



Thank you for selecting this new model portable air conditioner. Please safely keep this user manual for you later reading, and be sure to read this manual carefully before using the unit.

CONTENTS

1. IMPORTANT SAFEGUARD	3
2. FEATURES AND PARTS LIST.....	4
3. INSTALLATION	6
4. CONTROL AND SETTING.....	8
5. WATER-DRAINAGE.....	11
6. MAINTENANCE.....	12
7. TROUBLE SHOOTING.....	13
8. APPENDIX.....	14

Thank you for selecting this new model portable air conditioner. Please safely keep this user manual for you later reading, and be sure to read this manual carefully before using the unit.

IMPORTANT SAFEGUARDS

Important Safeguards.

- The appliance is for indoor use only.
- Read all instructions, Rated Power Supply: Please connect the unit with Grounded Power Sources: 220-240VAC, 50HZ.
- Disconnect the power plug before dismantling, assembling or before cleaning.
- Avoid touching mobile parts of the appliance.
- Never insert fingers, pencils or any other objects though the guard whenever the power plug is connected, especially while running.
- The appliance is not intended for use by young children or infirm persons unless they have been adequately supervised by a responsible person to ensure that they can use the unit safely.
- Young children should be supervised to ensure that they do not play with the appliance.
- Do not use the appliance for any other purposes than its intended use.
- The appliance is must not be used if the guards are not fasten according to the instructions.
- When the power cord is damaged, it must be replaced by the manufacturer or its service agent or a similar qualified person in order to avoid hazard
- Do not use your appliance with an extension cord unless it has been checked and tested by a qualified electrician or electrical supplier
- Return to authorized service agent.
- **The air conditioner unit must always be stored and transported upright, otherwise you may cause irreparable damage to the compressor; in case of doubt we suggest to wait for at least 24 hours before you start air-conditioning unit.**
- Avoid restarting the air conditioning unit unless 3 minutes have passed since being turned off, or the compressor may get damaged.
- Never use the mains plug as a switch to start and turn off the air conditioning unit. Use the provided ON/OFF switch located on the control panel.
- Always place the portable air conditioner on a dry stable place.
- The appliance shall not be installed in the laundry.
- The appliance must be positioned so that the plug is accessible. And it shall be installed in accordance with national wiring regulations.

Energy Saving Tips

- Do not cover or restrict the airflow from the Outlet or Inlet grills.
- The minimum distance from furniture and wall should be 50CM.
- Keep the filters clean. Under normal conditions, the filters should be cleaned approximately every 30 days. Since the filters remove airborne particles, more frequent cleaning maybe necessary, depending on the indoor air quality.
- Set the fan speed switch to high cool and the thermostat to the coolest position for the initial start-up, then set the fan switch to Low cool and lower the thermostat to a comfortable setting.

Suggestions:

If you want to get better effect, we suggest you not to use cooling function when ambient environment is higher than 35°C or heating function when the ambient environment is lower than 7°C .

FEATURES AND PARTS LIST

1、 Features

- Self evaporative system, no water tank.
- Oval and thin design, looks unique and luxury.
- Wing outlet closes automatically after shut down the unit, prevent dirt into machine. LCD display, indicating temperature and operation status.
- -Remote control and power plug can be put in the rear of the unit after use, exhaust hose could be fixed with the machine after use.
- New design handle, human oriented design
- Universal socket on the rear of the unit, easy to fix power plug.
- High position for pipe connection, easy to remove hot air.
- On/off timer function,
- Three -minutes -delay function for restarting, and some other protective function.

2、 Parts list:

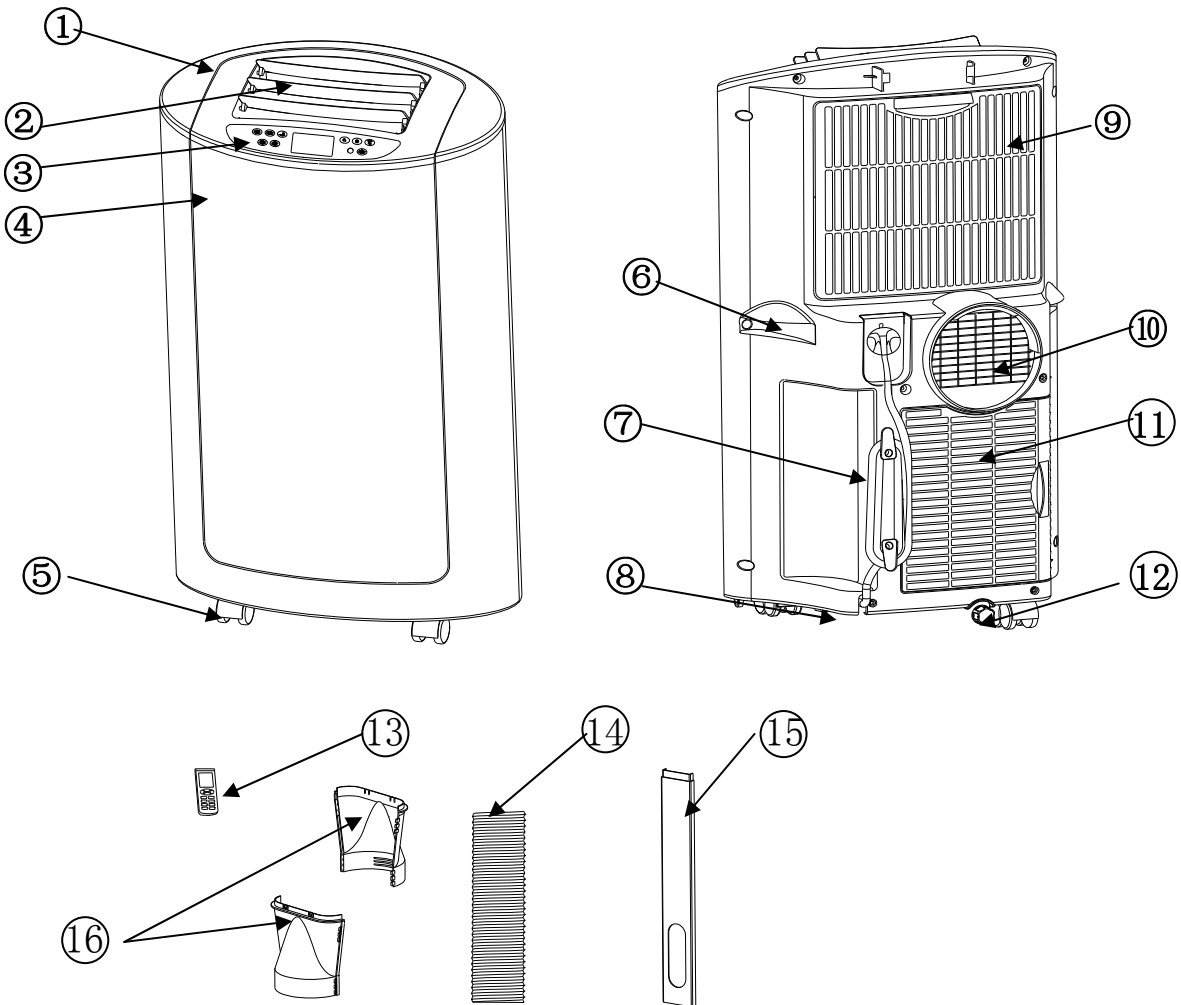

- 1. Top cover
- 2. Air outlet grille
- 3. Control panel
- 4. Front cover
- 5. Caster
- 6. Handle
- 7. Power cord
- 8. Drain port

- 9. Up filter frame
- 10. Protective net
- 11. Down filter frame
- 12. Water plug
- 13. Remote control
- 14. Exhaust hose
- 15. Window kits
- 16. Hose adaptor

INSTALLATION

1. Installation

Warning: Before using this unit, please keep it upright at least 2 hours.

The unit can be moved easily among the rooms, but please note the following:

1.1 Assemble hose adaptor (picture 1)

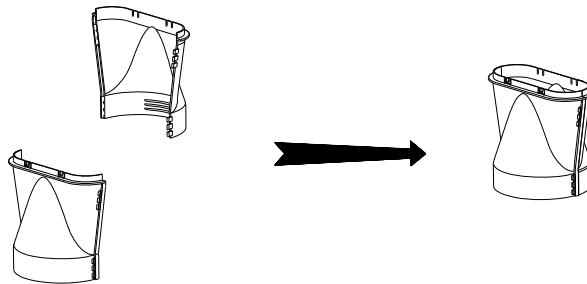

(picture 1)

- 1) Prepare male and female parts of hose adaptor, they are almost same on the structure
- 2) Each hand hold one part, you can connect them easily.

Remark: Don't push too hard to prevent damage.

1.2 Assembly of the exhaust hose (picture 2)

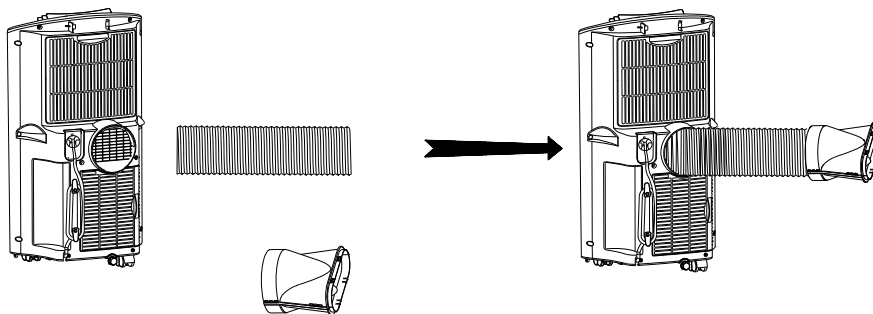

(picture 2)

- 1) Lengthen one head of the hose, screw it into the unit anti-clockwise.

Remarks: screw it to its place, no less than three circles.

- 2) The same way to connect the hose to the assembled adaptor(At least three circles)

1.3 Installation of window kits. Partially open the window and then fix the window kits to the window (picture 3,4 below).

The window kits can be installed on most normal and vertical windows, and it is adjustable.

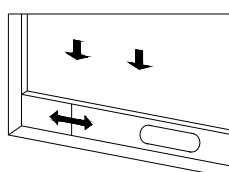

(Picture3)

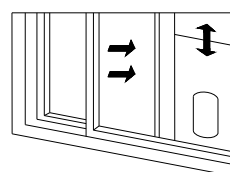

(Picture 4)

1.4 Please make sure the unit is upright. The unit should be put on the flat floor and 50cm to around objects.

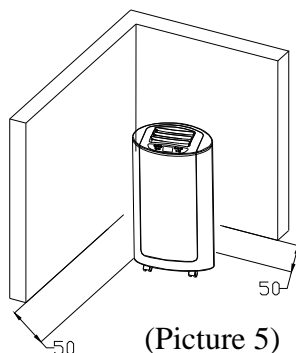

(Picture 5)

Fix the other end of the heat-exhausted hose to the air-outlet window kit (picture6, 7)

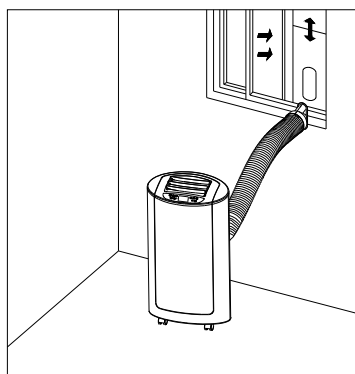

(Picture 6)



(Picture 7)

Important safeguards

The length of the soft hose is from 280 mm to 1500 mm which bases on the unit model. Don't use the lengthened hose or other hoses instead, or it might cause faults. The air-exhaustion must be well ventilated, if not, may cause the unit overheating.

Please note: Don't turn the air-exhausted pipe in vase scale($>45^\circ$)

CONTROL AND SETTING

This portable air conditioner of cooling only model has three functions: cooling, dehumidifying and fan. If the machine you purchased is cool and heat model, it has four functions cooling, heating, dehumidifying and fan









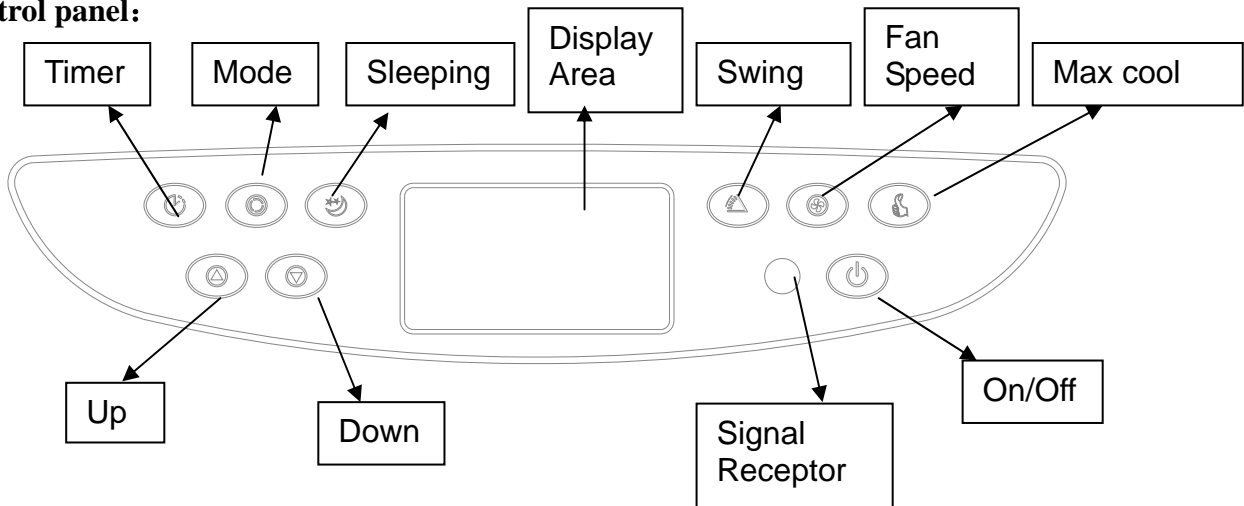

Fan has three speeds: high speed, middle speed and low speed,

Setting temperature is 18--30°C, 24 hours timer, water-throwing function, sensor and water-level protective function.

1、 Control instruction:









Control panel:



- 1.1 When plug in, follow the start music, unit is in standby status. Digital screen will indicate temperature(Range: 5~35°C/41~95°F),if ambient temperature above 35 °C,screen will show “H”. If it is below 5 °C, it will indicate “L” and the unit will enter standby status.
- 1.2 **ON/OFF**  button: When press this button, model will enter cooling mode (Setting temperature 24°C/75°F), high speed fan. Press again, unit will shut off and play shut-off music.
- 1.3 **Mode button**  :
Press this key to choose Cooling, Heating (only for cool & heat model)Fan , or Dehumidifying Mode.
- 1.4 **Fan button**  :
a) Under cooling mode:
HIGH FAN()→MIDDLE FAN()→LOW FAN()→HIGH FAN ()
→..., goes like this.
b) Under fan model: same as cooling mode
c) Under dehumidifying mode, fan is working in low speed
d) If switch between cooling and fan, fan speed won't change.
- 1.5 **Timer button**  :
Press it,  icon will flash, “88” areas indicates 24:00; you can set your time through  and  buttons. The HOUR number will change from 1,2,3...24; the Minute number will change from 10, 20,30...50.Auto-shut-off timer is only

available when the unit on; auto-run timer is only available when the unit is off.

After timer setting accomplishes effectively,  icon will keep on flashing until setting time is due. If set again, history record will be cleared.

- 1.6 **Up**  and **Down**  button: can set temperature and timer .
Under cooling or heating mode, the sting temperature ranges from 18~30°C/64~86°F.
If press Up  and Down  button simultaneously, the unit will shift between °C to °F.
- 1.7 **Sleeping key**  :
Under cooling or heating mode, press the key can make unit into sleeping mode,
LCD will show , press again to cancel.
- 1.8 **Swing button**  : press this key to start auto swing function, press again to cancel.
- 1.9 **Max cool key**  : Press this key to choose Max cool function: You can get cooling effect quickly under cooling mode.

2. Remote control



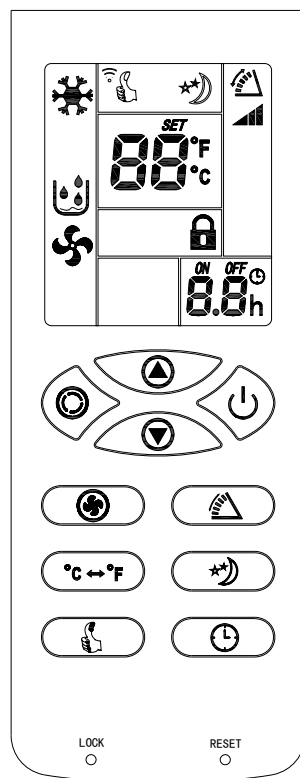

Drawing of Remote Control panel:

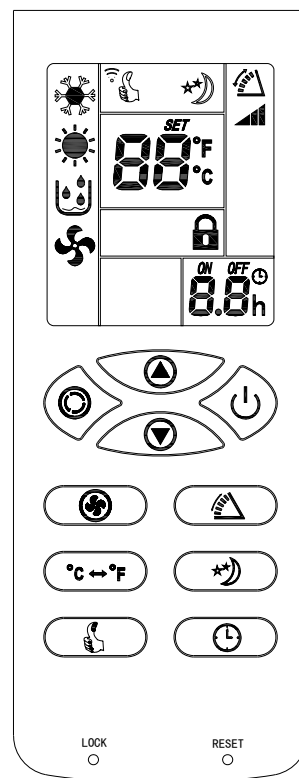







Remote control for Cool only



Remote control for Cool & Heat

1. **Power**  : Press this key to turn on/off the button.
2. **Mode**  : Press this key to choose cooling, heating, dehumidifying, fan
3. **Up**  : Press this key to turn up temperature or adjust time.
4. **Down**  : Press this key to turn down temperature or adjust time.

5. **Fan**  : Press this key to set low/middle/high fan speed.
6. **Swing**  : Press this key to control swing function.
7. **Temperature** $^{\circ}\text{C} \leftrightarrow ^{\circ}\text{F}$: Press this key to choose Centigrade or Fahrenheit.
8. **Sleeping**  (Only under cooling function): Press this key to enable this function.
9. **Timer**  : Press this key to set time. Within 5 hours, time interval is half hour; from 5 hours to 24 hours, time interval is 1 hour. Once set number will flash 5 times as confirmation .
10. **Max cool**  : Under cooling mode, press this key to achieve maximum output.
11. **Keypad lock**: Once set, press this key in use of something like a pin to lock all the button, as the screen will show image: , press this key again to unlock(This function can prevent kid from playing with the unit) .
12. **Reset**: Press this key by using something like a pin to reset remote control, default setting is cooling mode and high speed fan, auto swing.

3、 Multi protective function

3.1 Anti-freezing protecting control :

When the ambient temperature is very low under Cooling Mode, the compressor and water motor will stop working if the copper coil temperature $T_p < 2^{\circ}\text{C}$ for over 20 seconds after the compressor continues working for 10 minutes, the LCD Display E4; when copper coil temperature will increase $> 8^{\circ}\text{C}$, the protection will be stopped automatically, and recover to previous mode on the condition that compressor three-minutes delay protection satisfied.

3.2、 Water-full protection:

When the water level in the bottom water plate is surpassing warning level, the unit will alert automatically and “P2” will flashes on LCD. Please discharge water in the machine according to Chapter “Water Drainage”

3.3 Compressor delay-protection

Except for the first power-on, the compressor can start at once. In other cases, the compressor runs under 3 minutes delay protection.

3.4 No refrigerant protection

Under cooling, dehumidifying, heating mode, after compressor works for over 10 minutes, if the temperature difference of coil temperature and room temperature is less than 3°C for more than 30 minutes, the machine will enter no-refrigerant protection. That is to say, there is no refrigerant in the unit, compressor and water spring motor stop working, up fan runs with low speed, down fan stops running, E3 appears on LCD.

3.5 Press any key on the control panel , background light will turn bright from dark for 10 seconds.

WATER-DRAINAGE

1. Manual drainage :

1.1 When water tank is full and unit stop working, please shut off the unit and unplug

Please don't move the model sharply, or the water will spilt out from water received plate.

1.2 Use a water container to take water under the water plug.

1.3 Screw off the water plug and unplug the water blocker, water will come out to the water container.

1.4 Stuff up the water blocker and screw down the water plug.

2. Continue drainage:

2.1 Screw off the water plug and unplug the water blocker.

2.2 Use water pipe to connect the water outlet. Lead the pipe to the outside or washroom.

Remark: 1.This method can be done only if there is no water in the water received plate.

2.3 This model have self evaporative function, under cooling mode, please don't use continue drainage to get better cooling effect.

Maintenance

Cleaning.

Please shut off the unit and unplug the plug before cleaning or maintenance

Clean the surface

Clean the housing with a duster or a soft wet cloth. Do not use chemical solvent (such as benzene, alcohol, gasoline). The surface may be damaged or even the whole case may be deformed.

1. Air filter cleaning

1.1 Clean the air filters every 2 weeks. If the air filter is blocked with dust, the efficiency will reduce.

- 1) Pull out up and down filter as below pictures
- 2) Wash the air filters by immersing it gently into warm (about 40°C) water with a neutral detergent, rinse it and dry it thoroughly in a shaded place.
- 3) Install air filters carefully after cleaning the filters

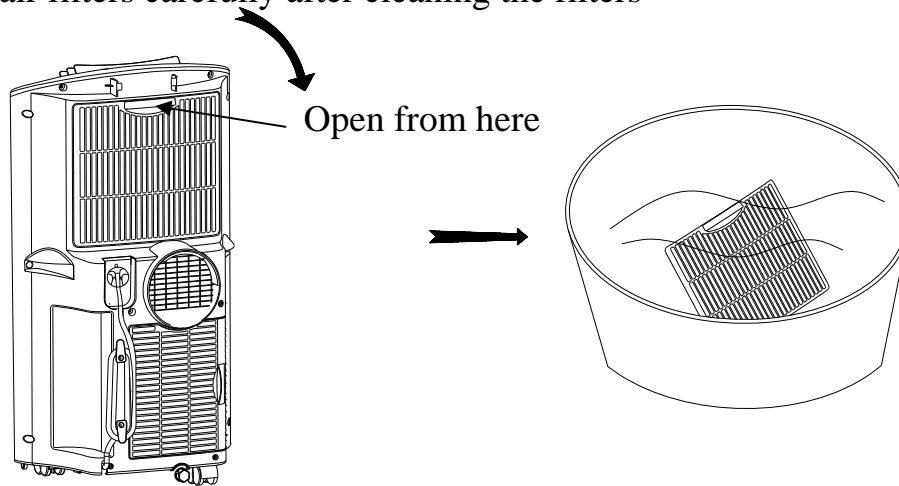

(picture 8)

Clean the air filter every 2 weeks. If the air filter is blocked with dust, the efficiency will reduce.

- 1). Outward and upward put out the air filter like picture 8 .
- 2) .Wash the air filter by immersing it gently into warm (about 40°C) water with a neutral detergent, rinse it and dry it thoroughly in a shaded place.
- 3).Put the air filter to its position in the unit.

Please note: active carbon filter cloth (choose the accessories depending on your needs) can be put out after putting out the filter frame and should be changed every 2-3 weeks based on the environment.

After Season Maintenance:

1. Pull out the plug in drainage hole and empty the water-received plate, or drain out the water by leaning the unit, then shift the unit mode to Fan mode, and press the button for 5 seconds till it to low fan speed. Keep this mode for half day till the conduit is dried. Doing like this can keep the inner unit dried and not go moldy.
2. Turn off the unit and pull out the plug.
3. Coil the wire and bind it together, then put it into the accessories room.
4. Separate the air-exhausted pipe and safely keep it.
5. Put the unit into a plastic bag, then keep it in a dried place.
6. Take out the batteries of remote control and safely keep them.

* All accessories can be put in the accessories room on the back of the unit.

Trouble Shooting

Don't repair or disassemble the unit by yourself, unsuitable repair may make the quality-protected card in vain, and even cause damage to the user or his/her possession.

Trouble	Reason	Solution
The unit doesn't work	No power supply	Power-on and turn on the unit.
	Water-full indicator illuminate	Drain out the inner stored water
	Timer function is active	Cancel Timer function
	Room temperature too low or too high?	Suggesting ambient temperature between 7-40℃
The unit does not seem to perform.	In direct sunlight.	Draw the curtains
	Windows or doors open, many people or a heat source in the room	Close windows and turn on another air conditioner
	Filter is very dirty	Clean or change the air filter
	Air inlet or air outlet is blocked	Clear out the stemming
	Room temperature is lower than setting temperature	Change the setting temperature
The unit noise is high	The unit is not put on flat place	Put the unit on flat and hard place(reduce noise)
Compress or doesn't work	Heat-exceeded protection is active	Re-start the unit 3 minutes later till the temperature low down.
Remote control doesn't work	The distance is too far.	Let the remote control near the unit and make sure it aims at the air-outlet grille
	Control panel hasn't received the signal from remote control.	
	The batteries run out.	Change the batteries
E1 on LCD	Coil temperature is abnormal	check coil temperature sensor or relevant circuit
E2 on LCD	Room temperature is abnormal	check room temperature sensor or relevant circuit
E4 on LCD	Anti-freezing protection	Waiting for defrosting, function will recover automatically
P2 on LCD	Water is full inside the machine	Drain out water from drain port at bottom rear of the unit.

If the solutions above don't function for the troubles, please contact with special service agent for help.

APPENDIX

Fuse Parameter

Type: FSD or 50F

Voltage: 250V

Current: 3.15A

The working principium diagram of the unit:

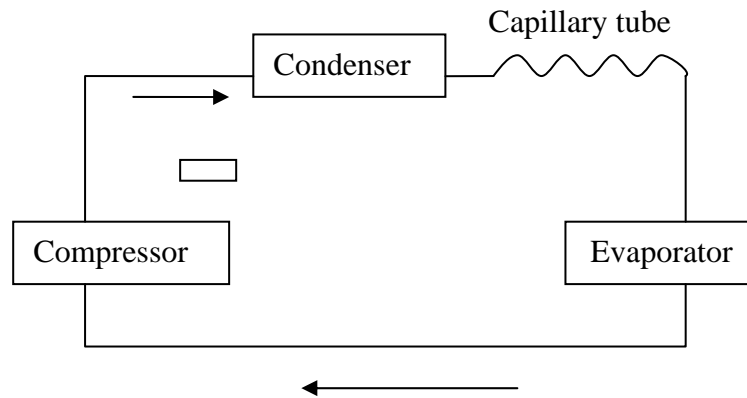

There is no further notice for the change of the parameters above, the exact parameters base on the rating plate.



Disposal: Do not dispose this product as unsorted municipal waste. Collection of such waste separately for special treatment is necessary.