

# QUARTZ GLASS TUBE PATIO HEATER INSTRUCTION MANUAL

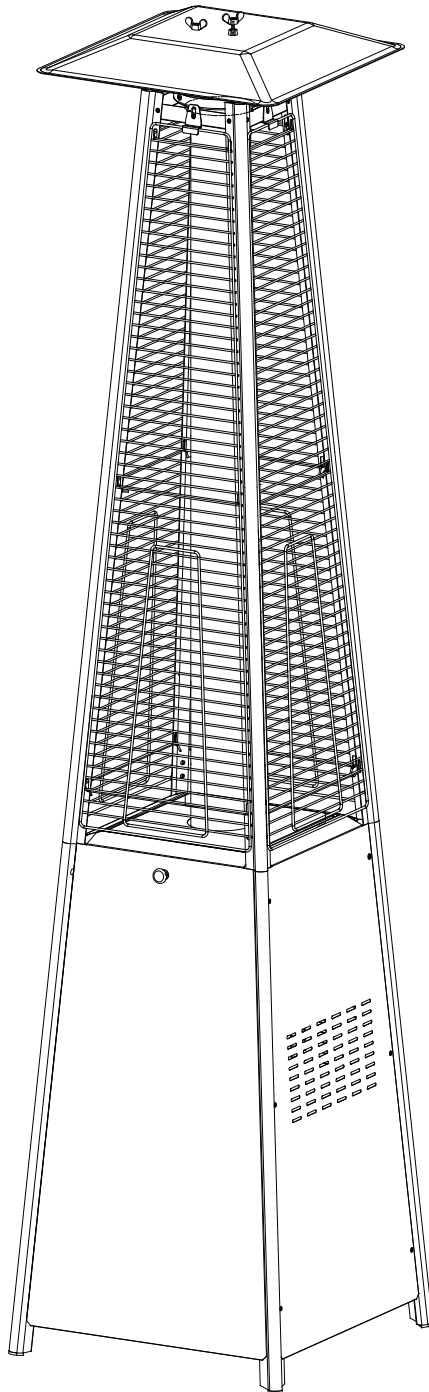

Keep the instructions for future reference

CE 14  
0063

# WARNING SAFETY RULES

PLEASE READ THE FOLLOWING SAFETY RULES PRIOR TO OPERATION OF THE HEATER

## ***FOR YOUR SAFETY***

If you smell gas:

1. Shut off gas to the appliance.
2. Extinguish any open flame.
3. If odor continues, immediately call your gas supplier or your fire Department.

## ***FOR YOUR SAFETY***

1. Do not store or use gasoline or other flammable vapors and liquids in the vicinity of this or any other appliance.
2. An LP cylinder not connected for use shall not be stored in the vicinity of this or any other appliance.

## WARNING

- 1) For use outdoors or in amply ventilated areas.
- 2) An amply ventilated area must have a minimum of 25 % of the surface area open.
- 3) The surface area is the sum of the walls surface.

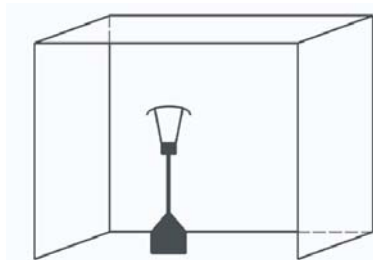

**WARNING:** Improper installation, adjustment, alteration, service or maintenance Can cause injury or property damage. Read the installation, operating and maintenance instructions thoroughly before installing or servicing this equipment.

# warning

## ***Read the instructions before installation and use.***

- This appliance must be installed and the gas cylinder stored in accordance with the regulations in force;
- Do not obstruct the ventilation holes of the cylinder housing;
- Do not move the appliance when in operation;
- Shut off the valve at the gas cylinder or the regulator before moving the appliance;
- The tubing or the flexible hose must be changed within the prescribed intervals;
- Use only the type of gas and the type of cylinder specified by the manufacturer;

The LP tank used with your patio heater must meet the following requirements:

Purchase LP tanks only with these required measurements:

(30.5cm) (diameter) x 57.1 cm) (tall) with 23kg capacity maximum.

- In case of violent wind particular attention must be taken against tilting of the appliance;

# TABLE OF CONTENTS

Caution .....	1
Heater Stand and Location .....	2
Gas Requirements .....	2
Leakage Test .....	2
Operation and Storage .....	3
Cleaning and Care .....	4
Parts and Specifications .....	4
Assembly Parts and Procedures .....	6
Problems Check List .....	16

# CAUTION

## PLEASE READ CAREFULLY THE FOLLOWING SAFETY GUIDELINES BEFORE OPERATION.

- Do not use the patio heater for indoors, as it may cause personal injury or property damage.
- This outdoor heater is not intended to be installed on recreational vehicles and/or boats.
- Installation and repair should be done by a qualified service person.
- Improper installation, adjustment, alteration can cause personal injury or property damage.
- Do not attempt to alter the unit in any manner.
- Never replace or substitute the regulator with any regulator other than the factory-suggested replacement.
- Do not store or use gasoline or other flammable vapors or liquids in the heater unit.
- The whole gas system, hose, regulator, pilot or burner should be inspected for leaks or damage before use, and at least annually by a qualified service person.
- All leak tests should be done with a soap solution. Never use an open flame to check for leaks.
- Do not use the heater until all connections have been leak tested.
- Turn off the gas valve immediately if smell of gas is detected. Turn Cylinder Valve OFF. If leak is at Hose/Regulator connection: tighten connection and perform another leak test. If bubbles continue appearing should be returned to hose's place of purchase. If leak is at Regulator/Cylinder Valve connection: disconnect, reconnect, and perform another leak check. If you continue to see bubbles after several attempts, cylinder valve is defective and should be returned to cylinder's place of purchase.
- Do not transport heater while it's operating.
- Do not move the heater after it has been turned off until the temperature has cooled down.
- Keep the ventilation opening of the cylinder enclosure free and clear of debris.
- Do not paint the radiant screen, control panel or top canopy reflector.
- Control compartment, burner and circulation air passageways of the heater must be kept clean. Frequent cleaning may be required as necessary.
- The LP tank should be turned off when the heater is not in use.
- Check the heater immediately if any of the following occurs:
  - The heater does not reach temperature.
  - The burner makes popping noise during use (a slight noise is normal when the burner is extinguished).
  - Smell of gas in conjunction with extreme yellow tipping of the burner flames.
- The LP regulator/hose assembly must be located out of pathways where people may trip over it or in area where the hose will not be subject to accidental damage.
- Any guard or other protective device removed for servicing the heater must be replaced before operating the heater.
- Adults and children should stay away from high temperature surface to avoid burns or clothing ignition.
- Children should be carefully supervised when they are in the area of the heater.
- Clothing or other flammable materials should not be hung on the heater or placed on or near the heater.
- To change the gas cylinder in a amply ventilated area, away from any ignition source (candle, cigarettes, other flame producing appliances, ...);
- To check that the regulator seal is correctly fitted and able to fulfill its function showed as photo right;
- To not obstruct the ventilation holes of the cylinder housing;
- To close the gas supply at the valve of the gas cylinder or the regulator after use;
- In the event of gas leakage, the appliance shall not be used or if alight, the gas supply shall be shut off and the appliance shall be investigated and rectified before it is used again;
- To check the hose at least once per month, each time the cylinder is changed, or each time before long time no use. If it shows signs of cracking, splitting or other deterioration it shall be exchanged for new hose of the same length and of the equivalent quality;
- The use of this appliance in enclosed areas can be dangerous and is PROHIBITED;
- Read the instructions before using this appliance. The appliance must be installed in accordance with the instructions and local regulations.
- For connection of hose and regulator, and connection of regulator and hose, please refer to photo showed above.

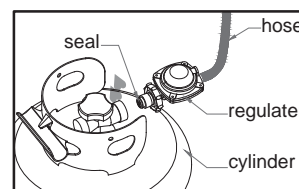

Hose/ Regulator connection and  
Regulator / Cylinder connection

## HEATER STAND AND LOCATION

- The heater is primarily for outdoor use only. Always ensure that adequate fresh air ventilation is provided.
- Always maintain proper clearance to non protected combustible materials i.e. top 100 cm and sides 100 cm minimum.
- Heater must be placed on level firm ground.
- Never operate heater in an explosive atmosphere like in areas where gasoline or other flammable liquids or vapors are stored.
- To protect heater from strong wind, anchor the base securely to the ground with screws.

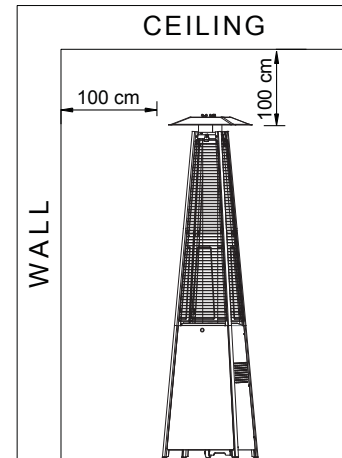

## GAS REQUIREMENTS

- Use propane, butane or their mixtures gas only.
- The pressure regulator and hose assembly to be used must conform to local standard codes.
- The installation must conform to local codes, or in the absence of local codes, with the standard for the storage and handling of liquid petroleum gases.
- A dented, rusted or damaged tank may be hazardous and should be checked by your tank supplier. Never use a tank with a damaged valve connection.
- The tank must be arranged to provide for vapor withdrawal from the operating cylinder.
- Never connect an unregulated tank to the heater.

## LEAKAGE TEST

Gas connections on the heater are leak tested at the factory prior to shipment. A complete gas tightness check must be performed at the installation site due to possible mishandling in shipment or excessive pressure being applied to the heater.

- Make a soap solution of one part liquid detergent and one part water. The soap solution can be applied with a spray bottle, brush or rag. Soap bubbles will appear in case of a leak.
- The heater must be checked with a full cylinder.
- Make sure the safety control valve is in the OFF position.
- Turn the gas supply ON.
- In case of a leak, turn off the gas supply. Tighten any leaking fittings, then turn the gas supply on and re-check.
- Never leak test while smoking.

# OPERATION AND STORAGE

## TO TURN ON THE HEATER

1. Turn on the valve on the gas supply cylinder completely.
2. Press and turn the variable control knob to PILOT position (counter-clockwise 90°).
3. Press down the variable control knob and hold for 30 seconds. While holding down the variable control knob, press the igniter button several times until the pilot flame lights. Release the variable control knob after the pilot flame lights.

Note:

- If a new tank has just been connected, please allow at least one minute for the air in the gas pipeline to purge out through the pilot hole.
  - When lighting the pilot flame make sure that the variable control knob is continuously pressed down while pressing the igniter button. Variable control knob can be released after the pilot flame lights.
  - If the pilot flame does not light or it goes out, repeat step 3.
4. After the pilot flame lights, turn the variable control knob to maximum position and leave it there for 5 minutes or more before turning the knob to desired temperature position.

**Warning:** *check that no broken on the glass is found before operation.*

## TO TURN OFF THE HEATER

1. Turn the variable control knob to PILOT position.
2. Press and turn the variable control knob to OFF position.

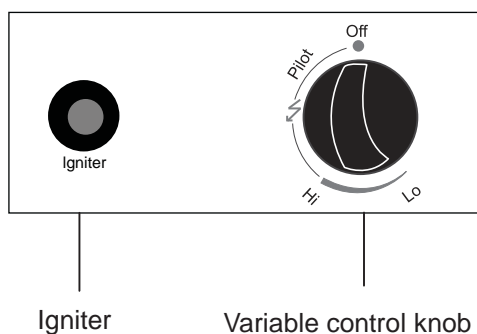

Off: the heater stop work  
Hi: maximum temperature position  
Lo: minimum temperature position

3. Turn off the valve on the gas supply cylinder completely.

## **Storage**

1. Always close the gas valve of the gas cylinder after use or in case of a disturbance.
2. Remove the pressure regulator and the hose.
3. Check the tightness of the gas valve and for damage. If you suspect a damage, have it changed by your gas dealer.
4. Never store liquid gas cylinder in a sub-terrain, or at places without adequate air ventilation.

# CLEANING AND CARE

- Wipe off powder coated surfaces with soft, moist rag. Do not clean heater with cleaners that are combustible or corrosive.
- Remove debris from the burner to keep it clean and safe for use.
- Cover the burner unit with the optional protective cover when the heater is not in use.

# PARTS AND SPECIFICATIONS

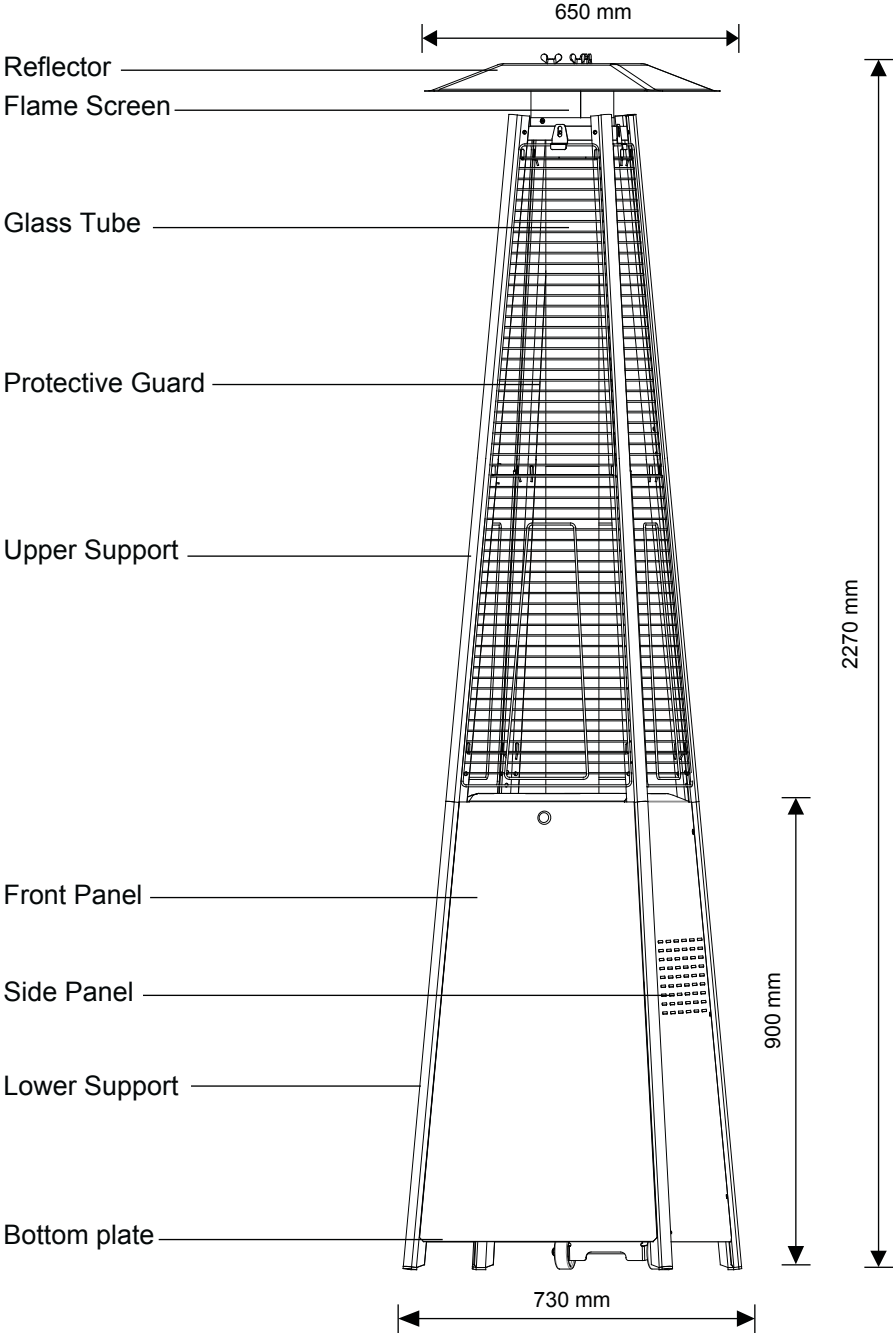



### A. Construction and characteristics

- Transportable terrace/garden heater with tank housing.
- Casing in steel with powder-coating or in stainless steel.
- Gas hose connections with metal clamp (screw caps for Germany).
- Heat emission from reflector.

### B. Specifications

- Use propane, butane or their mixtures gas only.
- Max. wattage: 13000 watts
- Min. wattage: 5000 watts
- Consumption:

APPLIANCE CATEGORY:	I <sub>3+</sub> (28-30/37)		I <sub>3B/P</sub> (30)	I <sub>3B/P</sub> (50)	I <sub>3B/P</sub> (37)
TYPES OF GAS:	Butane	Propane	Butane, propane or their mixtures	Butane, propane or their mixtures	Butane, propane or their mixtures
GAS PRESSURE:	28-30mbar	37 mbar	30 mbar	50mbar	37mbar
OUTLET PRESSURE OF REGULATOR:	30mbar	30 mbar	30 mbar	50mbar	37mbar

- Using the proper regulator according to outlet pressure of regulator as showed in the table above.

### C. Table of injector

APPLIANCE CATEGORY:	I <sub>3+</sub> (28-30/37)		I <sub>3B/P</sub> (30)	I <sub>3B/P</sub> (50)	I <sub>3B/P</sub> (37)
TYPES OF GAS:	Butane	Propane	Butane, propane or their mixtures	Butane, propane or their mixtures	Butane, propane or their mixtures
GAS PRESSURE:	28-30mbar	37 mbar	30 mbar	50mbar	37mbar
TOTAL HEAT INPUT (Hs): (Qn)	13kW (945g/h)				
INJECTOR SIZE:	1.88 mm for main burner 0.18 mm for pilot burner			1.55 mm for main burner 0.18 mm for pilot burner	1.65 mm for main burner 0.18 mm for pilot burner
The marking, for example, 1.88 on the injector, indicates that the size of injector is 1.88mm					

- The hose and regulator assembly must conform to local standard codes.
- Regulator outlet pressure should meet the corresponding appliance category in B. Specification.
- The appliance requires approved hose in 0.6m length.

# ASSEMBLY PARTS

## Tools needed:

- Philips screwdriver w/ medium blade
- Spray bottle of soap solution for leakage test

## Parts List:

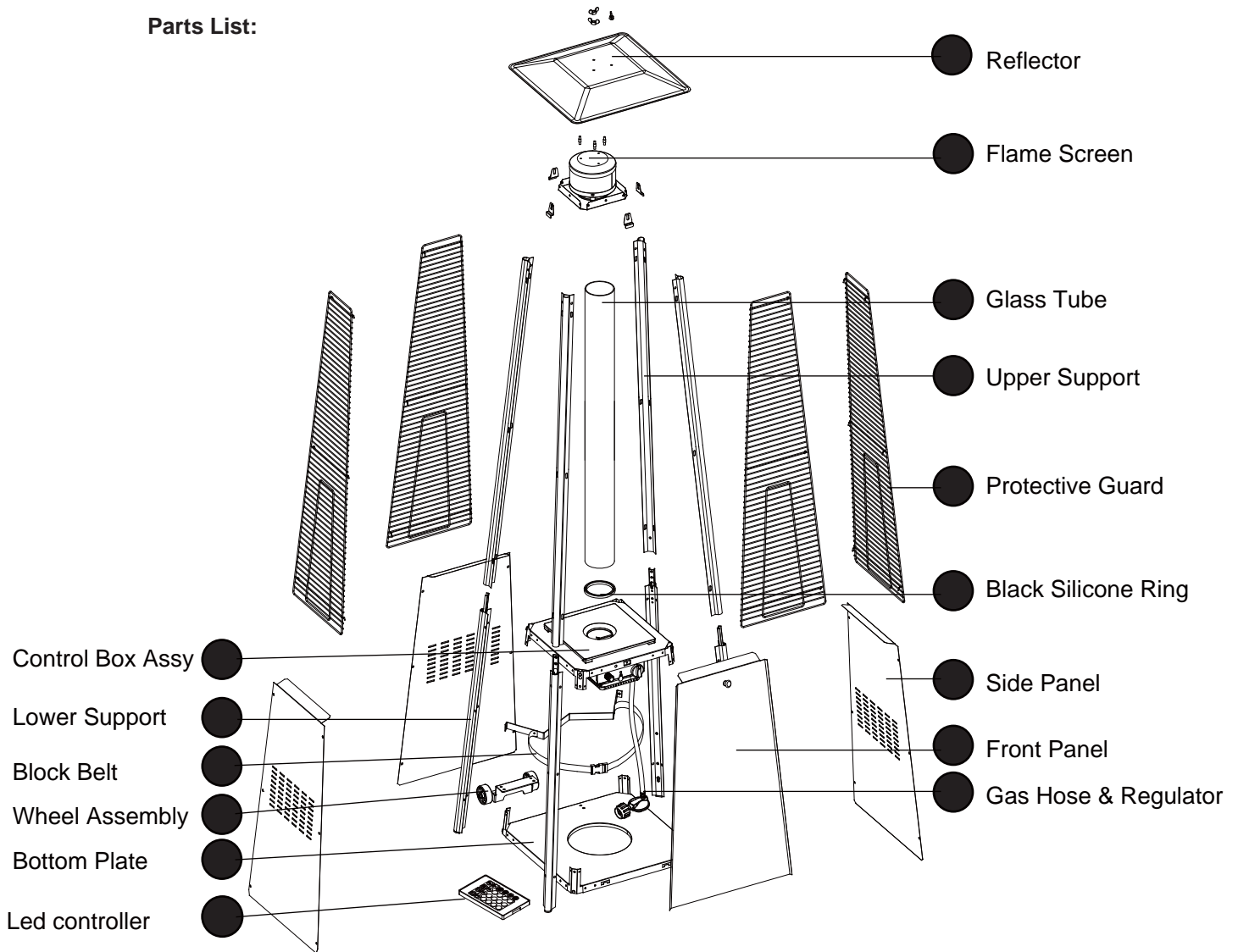









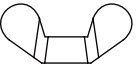

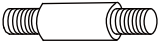
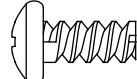
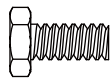

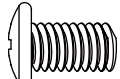
PART	DESCRIPTION	QUANTITY
A	Reflector	1
B	Flame Screen	1
C	Glass Tube	1
D	Upper Support	4
E	Protective Guard	4
F	Black Silicone Ring	1
G	Side Panel	3
H	Front Panel	1
I	Gas Hose & Regulator	1
J	Control Box Assy	1
K	Lower Support	4

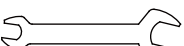
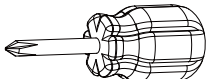
PART	DESCRIPTION	QUANTITY
L	Block Belt	1
M	Wheel Assembly	1
N	Bottom Plate	1
O	Led controller	1

# ASSEMBLY PARTS

HARDWARE CONTENTS (shown actual size)

- |  |  |  |   |  |  |
|--|--|--|---|--|--|
| <br><b>AA</b> | <br><b>BB</b> | <br><b>CC</b>   | <br><b>DD</b> | <br><b>EE</b> | <br><b>FF</b> |
| Wing nut<br>Qty. 3   | Small flat<br>washer $\Phi 6$<br>Qty. 6  | Stud<br>Qty. 3   | 3/16" Screw<br>Qty. 42  | Bolt M6 X 12<br>Qty. 4   | M6<br>Flange<br>nut<br>Qty. 4  |
| <br><b>GG</b> | <br><b>HH</b> | <br><b>JJ</b>   | <br><b>KK</b> | <br><b>LL</b> | <br><b>MM</b> |
| Screw<br>M5 X 12<br>Qty. 6   | Fixing Bracket<br>Qty. 4   | Wrench<br>Qty. 1   | Philips<br>screwdriver<br>Qty. 1  | Knob<br>Qty. 1   | Screw<br>M4 X 10<br>Qty. 1   |
| <br><b>NN</b> | <br><b>OO</b> | <br><b>PP</b> |   |  |  |
| Chain<br>Qty. 1  | Long Stem Lighter<br>Qty. 1  | Wafer<br>Qty. 1  |   |  |  |

## ASSEMBLY PROCEDURES

1. Assemble the wheel assembly to the bottom plate. Fix the wheel assembly to the bottom plate using 4pcs bolt M6X12 and 4pcs flange nut M6.

### Hardware Used

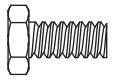
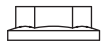
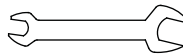
<b>EE</b>	Bolt M6 X 12		x 4
<b>FF</b>	M6 Flange nut		x 4
<b>JJ</b>	Wrench		x 1

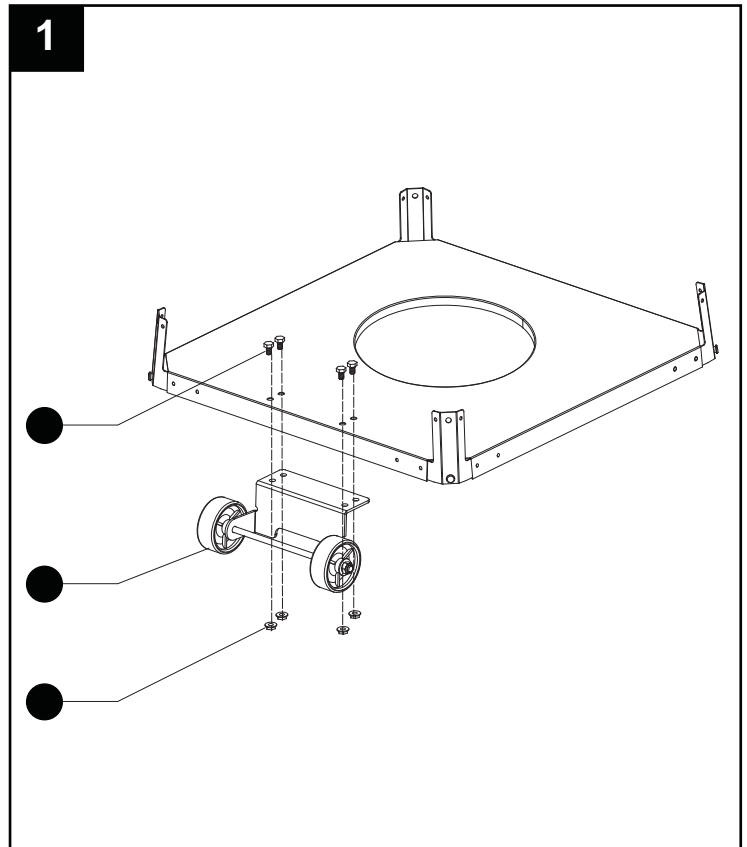

2. Insert the pins of the base to the holes of lower support, press to secure the pins. Using 4pcs screw M5x12 to secure the lower support and base.

Insert the pins of the control box assy to the holes of upper support, press to secure the pins. Using 4pcs screw 3/16" screw to secure the upper support and control box assy.

### Hardware Used

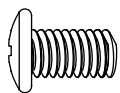
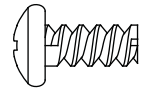
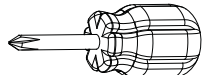
<b>GG</b>	Screw M5 X 12		x 4
<b>DD</b>	3/16" Screw		x 4
<b>KK</b>	Philips screwdriver		x 1

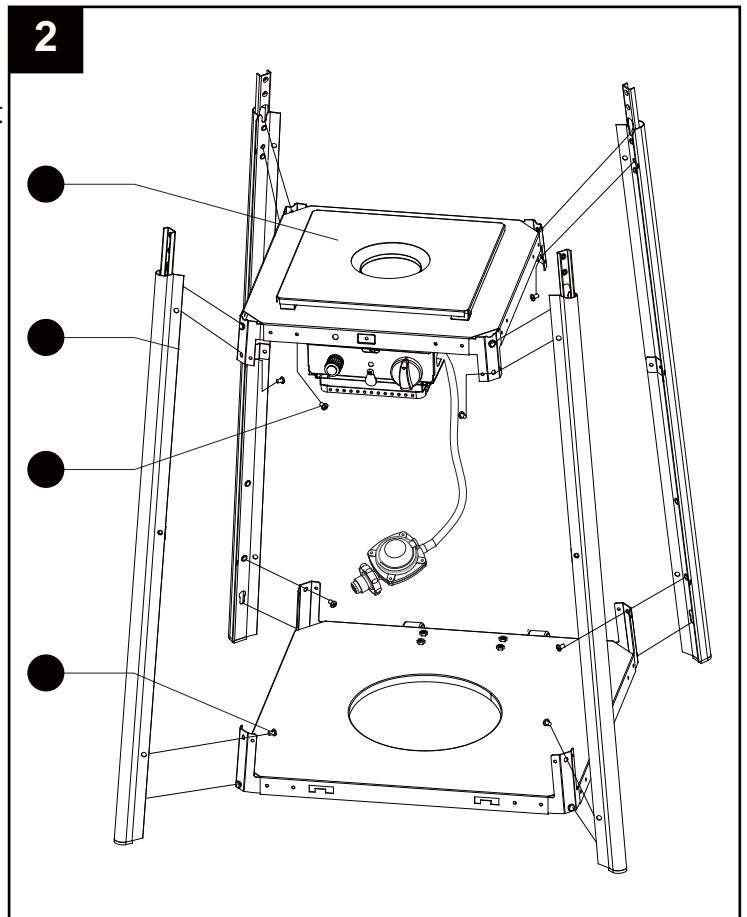

3. Assemble block belt.  
 Fix the block belt to the 2pcs of lower support behind the front door, using 2pcs screw M5X12.

**Hardware Used**

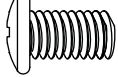
**GG** Screw M5 X 12  x 2

**KK** Philips screwdriver  x 1

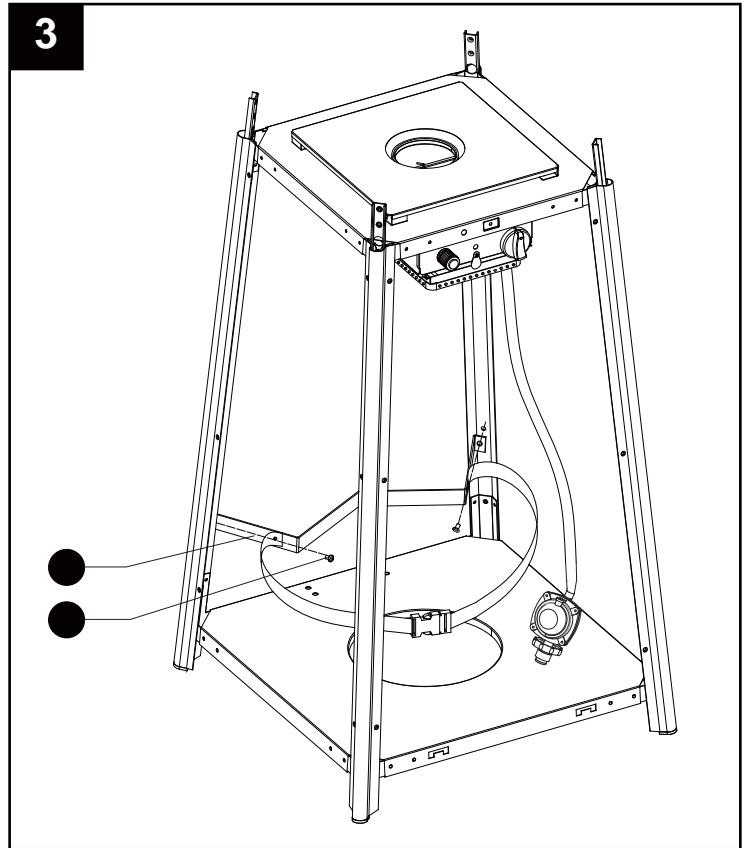

4. Assemble the middle support.  
 Insert the 4pcs upper support to the lower support. Secure them with 8pcs screw 3/16”.

**Hardware Used**

**DD** 3/16” Screw  x 8

**KK** Philips screwdriver  x 1

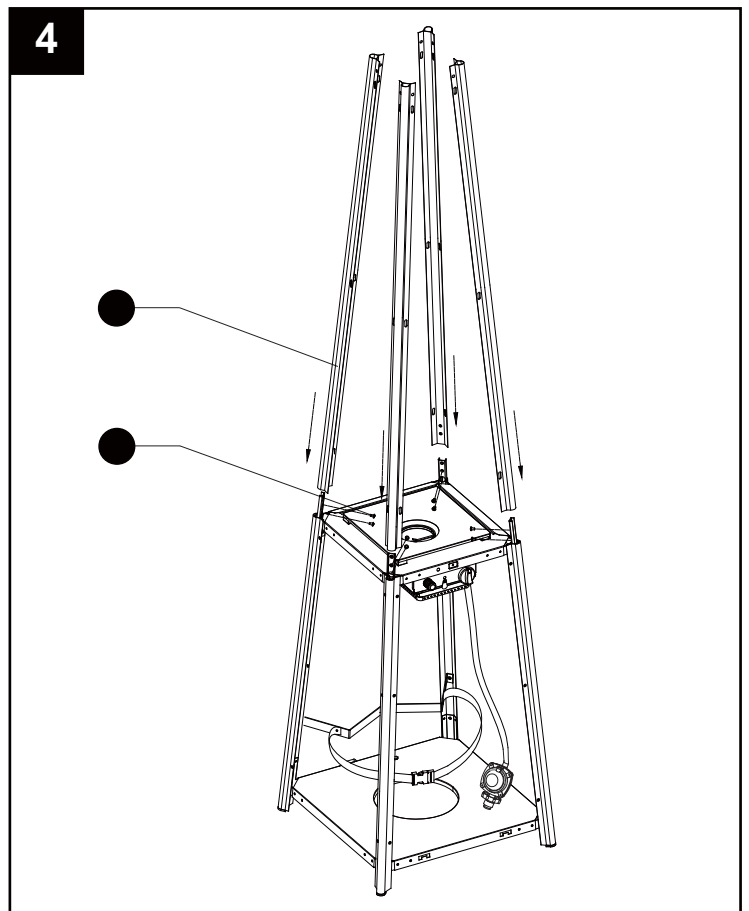

5. Assemble the flame screen to the upper support.  
Secure the flame screen to the upper support using 8pcs screw 3/16”.

**Hardware Used**

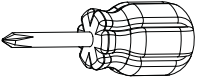
- DD** 3/16” Screw  x 8
- KK** Philips screwdriver  x 1

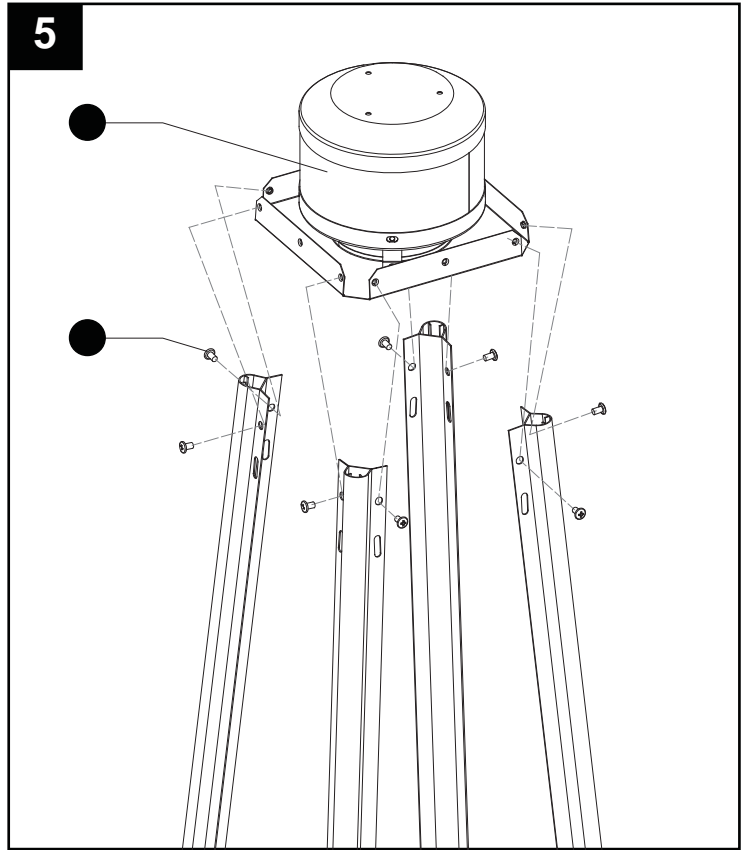

6. Assemble the reflector onto the flame screen.  
Screw the 3pcs stud on the flame screen, put 3pcs washer  $\Phi 6$  onto the top of stud, then put the reflector onto the stud, secure them with 3pcs washer  $\Phi 6$  and 3pcs wing nut.

**Hardware Used**

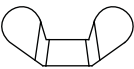
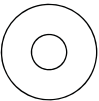
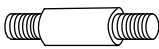
- AA** Wing nut  x 3
- BB** Washer  $\Phi 6$   x 6
- CC** Stud  x 3

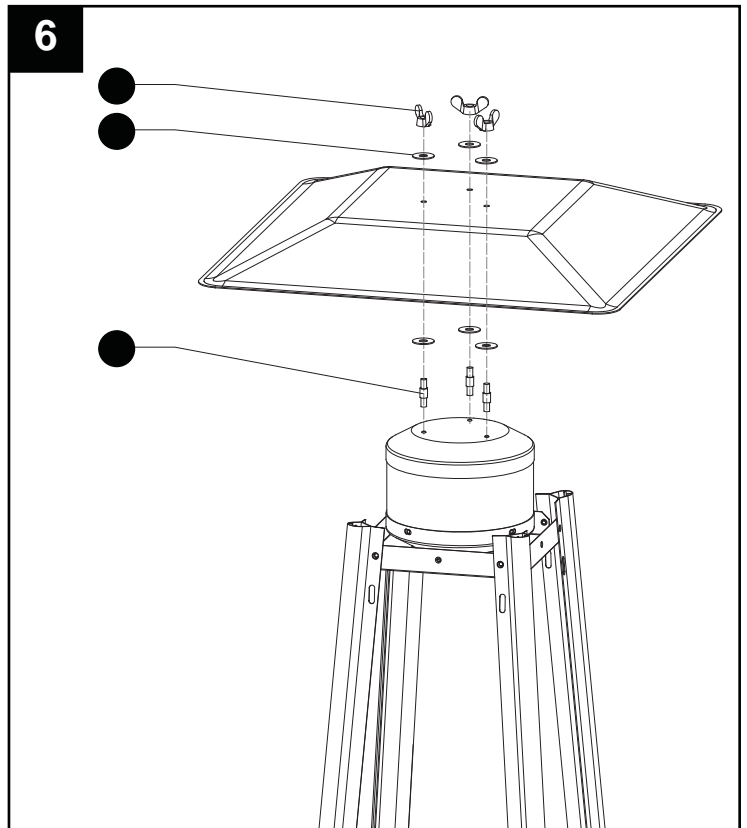

7. Carefully install the glass tube by lifting up and inserting through the center hole in the upper plate. Ensure the black silicone ring is attached to the lower edge of the glass tube as illustrated. Slide the glass tube through the hole of the lower plate cover and onto the middle plate. Check and ensure that the glass tube is positioned properly and is completely covering the center hole of the middle plate.

**WARNING! The black silicone ring must be in place prior to operating the heater.**



8. Assembly the protective guard. Hang the hooks of the protective guard onto the holes in supports. Secure the protective guards with fixing brackets with 4pcs 3/16" screws.

**Hardware Used**

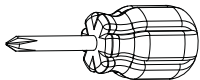
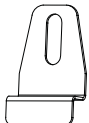
- |           |                     |   |     |
|-----------|---------------------|---|-----|
| <b>DD</b> | 3/16" Screw         |  | x 4 |
| <b>KK</b> | Philips screwdriver |  | x 1 |
| <b>HH</b> | Fixing Bracket      |  | x 4 |

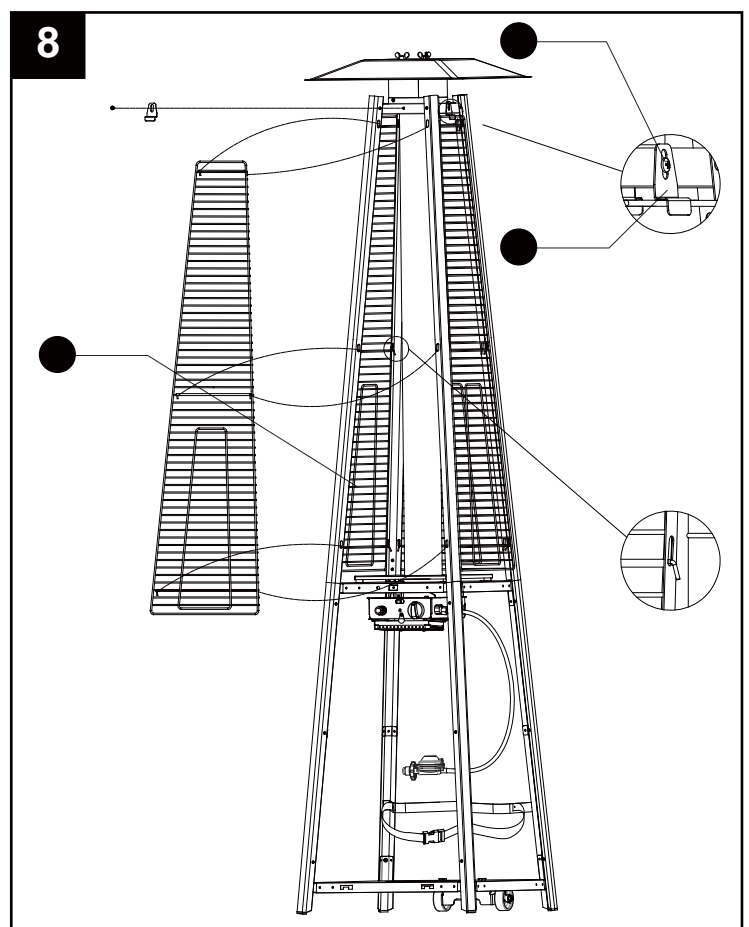

9. Attach the three side panels to the heater using 18pcs screw 3/16".  
 Note : Do not cover the front side where the control knob is.



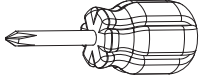

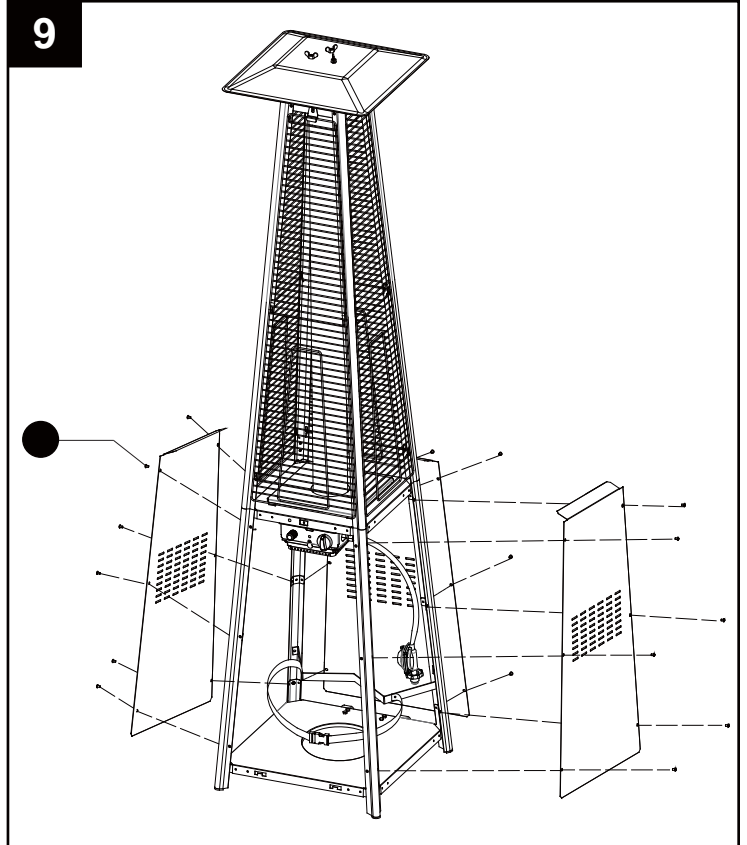
**Hardware Used**

- DD** 3/16" Screw  x 18
- KK** Philips screwdriver  x 1

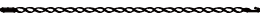

10. Assemble the chain and wafer to the inside of front panel with M4x10 screw, then install the knob to M4x10 screw. Hang the chain to the hole on the control box assy and put the pothook of front panel to the holes of bottom plate.

**Hardware Used**

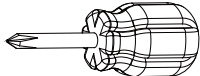
- LL** Knob  x 1
- MM** Screw M4 X 10  x 1
- NN** Chain  x 1
- PP** wafer  x 1
- KK** Philips screwdriver  x 1

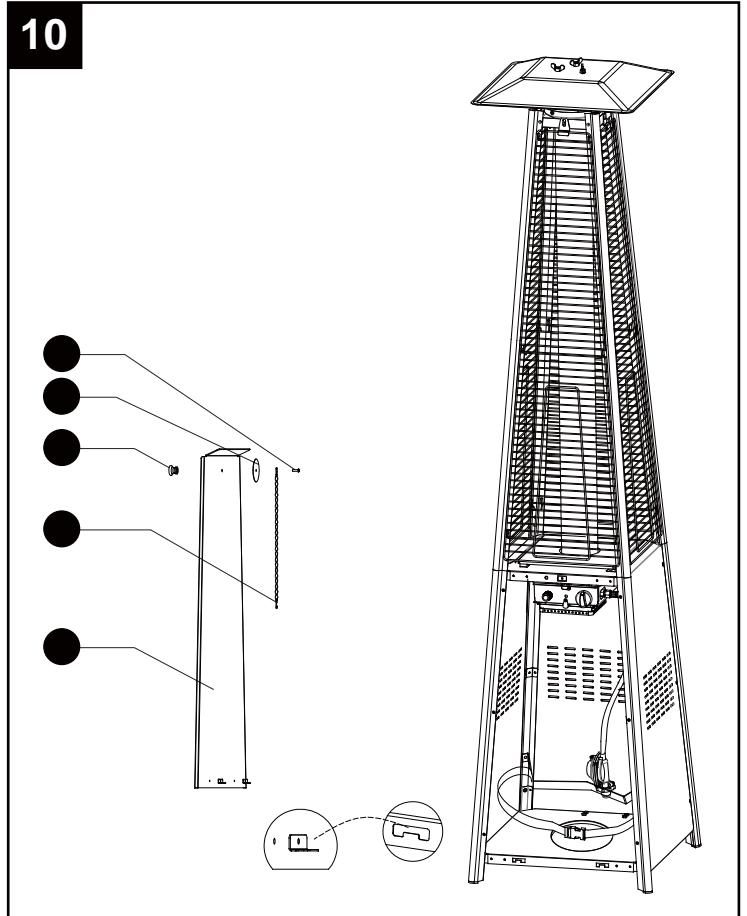



11. Propane Only-Proper Hose Connection.

**!** **WARNING!** Ensure the hose does not contact any high temperature surfaces, or it may melt and leak causing a fire.

After the cylinder is placed inside the heater, secure the cylinder with block belt tightly.

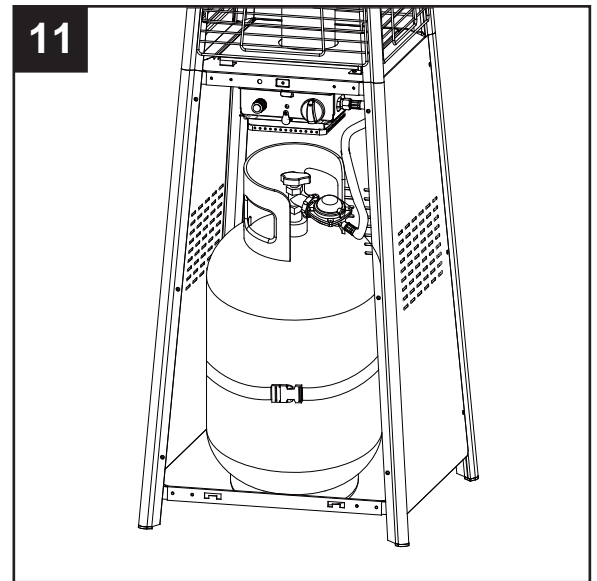

12. Leak Check.



**WARNING!** A leak test must be performed annually and each time a cylinder is hooked up or if a part of the gas system is replaced.



**WARNING!** Never use an open flame to check for gas leaks. Be certain no sparks or open flames are in the area while you check for leaks. Sparks or open flames will result in a fire or explosion, damage to property, serious bodily injury, or death.



**Leak testing:** This must be done before initial use, annually, and whenever any gas Components are replaced or serviced. Do not smoke while performing this test, and remove all sources of ignition. See Leak Testing Diagram for areas to check. Turn all burner controls to the off position. Turn gas supply valve on.



Brush a half-and-half solution of liquid soap and water onto all joints and connections of the regulator, hose, manifolds and valves.



Bubbles will indicate a gas leak. Either tighten the loose joint or have the part replaced with one recommended by the Customer Care department and have the patio heater inspected by a certified gas installer.

If the leak cannot be stopped, **immediately shut off the gas supply**, disconnect it, and have the patio heater inspected by a certified gas installer or dealer. Do not use the patio heater until the leak has been corrected.

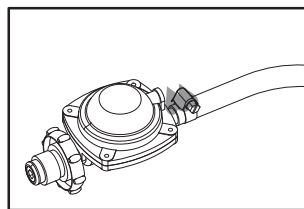

Hose / Regulator connection

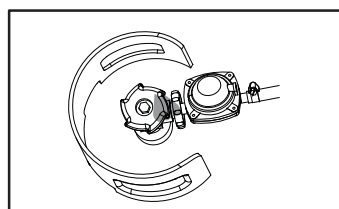

Regulator / Cylinder connection

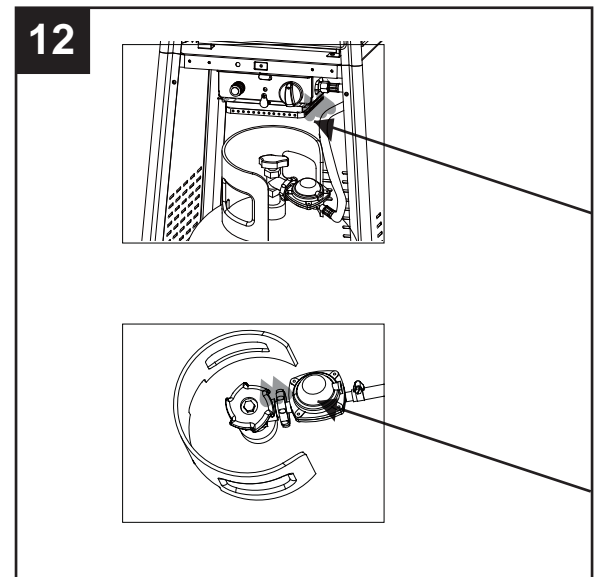

## ASSEMBLY INSTRUCTIONS

12. LED belt box and battery box installation.

12-1. The normal position of block chip like figure a.

12-2. Adjust the position of block chip like figure b. Pull out the LED belt box.

12-3. When change the batteries, first take out the LED belt box and then battery box, after that open the battery box and change the batteries like figure c.

12

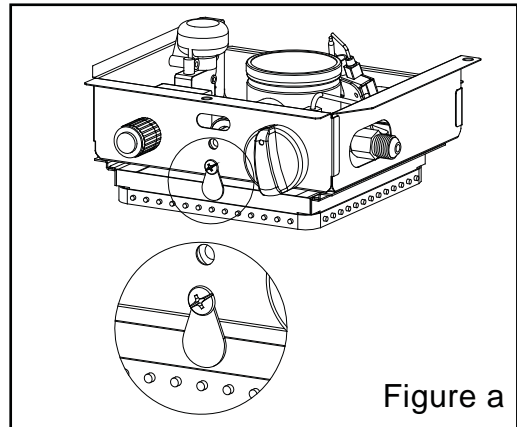

Figure a

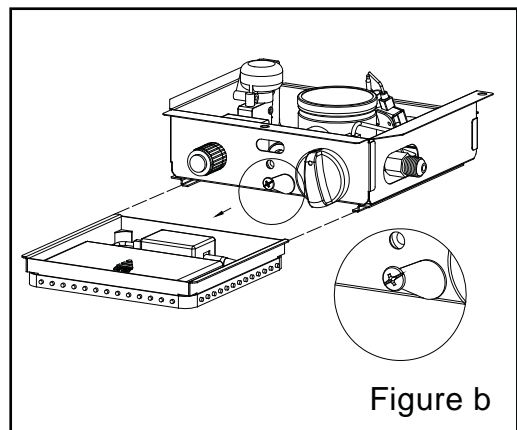

Figure b

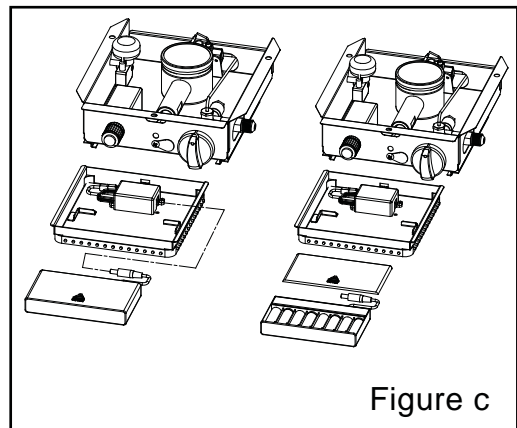

Figure c

## ASSEMBLY INSTRUCTIONS

### Operation Instructions of Controller

#### 1.Specifications:

Working temperature:-20-60℃

Supply voltage:DC12V

Product size:L62×W35×H23mm

Package size:L105×W65×H55mm

Net weight:50g Gross weight:70g

Output:Three CMOS drain-open output

Connecting Mode:Common anode

Max load current:2 A each color

#### 2.Control Method:

Adopt IR remoter to control the led controller,which has 24 buttons,the function of each button as the table below:

Brightness+(Speed up)	Brightness-(Speed down)	Off	On
Static red	Static green	Static blue	Static white
Static orange	Static pea green	Static dark blue	7color jumpy change
Static dark yellow	Static cyan	Static brown	All fade out&fade in
Static yellow	Static light blue	Static pink	7color fade change
Static straw yellow	Static sky blue	Static puple	3 base color jumpy

#### 3.Panel specification and connecting drawing as follows:

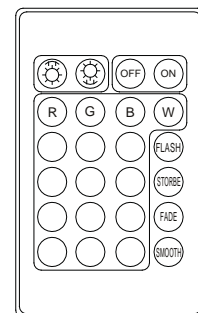
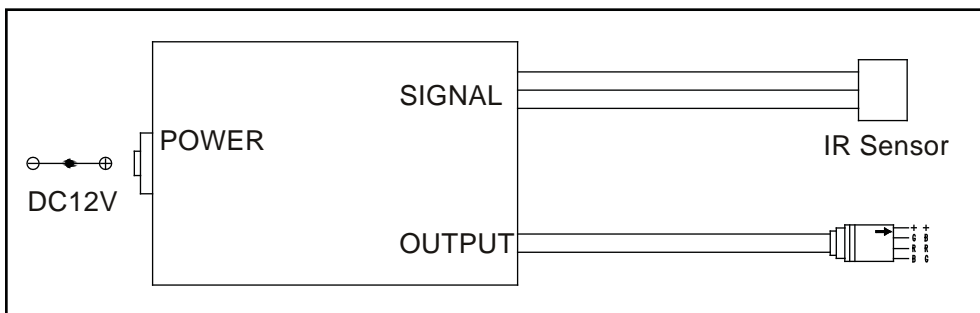

#### 4.Warning:

- Supply voltage of this product is DC12V never connect to DC24V or AC220V.
- Never connect two wires directly in case of short circuit.
- Lead wire should be connected correctly according to colors that connecting diagram offers.
- Warranty of this product is one year,in this period we guarantee replacement or repairing with no charge,but exclude the artificial situation of damaged or overload working.

#### 5. Replace the remote control battery:

The remote control for LED light is powered by a Model CR2025 3V battery. if you can't use it to control the LED light at closer position, its battery may be exhausted. please push and pull out the battery bracket to replace the battery. Like the instruction at the back of the remote control.

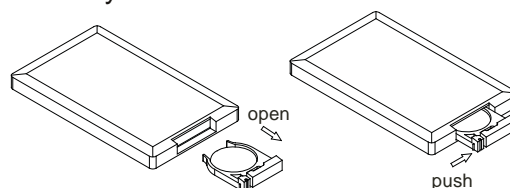

# PROBLEMS CHECK LIST

<b><u>PROBLEM</u></b>	<b><u>PROBABLE CAUSE</u></b>	<b><u>SOLUTION</u></b>
Pilot will not light	Gas valve may be OFF Tank fuel empty Opening blocked Air in supply system Loose connections	Turn the gas valve ON Refill LPG tank Clean or replace opening Purge air from lines Check all fittings
Pilot will not stay on	Debris around pilot Loose connections Thermocouple bad Gas leak in line Lack of fuel pressure	Clean dirty area Tighten connections Replace thermocouple Check connections Tank near empty. Refill LPG tank.
Burner will not light	Pressure is low Opening blocked Control not ON Thermocouple bad Pilot light assembly bent Not in correct location	Tank near empty. Refill LPG tank. Remove and clean Turn valve to ON Replace thermocouple Place pilot properly Position properly and retry

If the appliance is in case of any defaults or problems of assembly or use, please don't try to modify it by yourself, contact your supplier or distributor to solve it.